

INDEX	MDSL0031-05
REV. LEVEL	4
SHEET	1 OF 1

TOSHIBA/HOUSTON TOTALLY-ENCLOSED FAN-COOLED Fr. 284T-286T
EQP III "XS" & "841" HORIZONTAL FOOT-MOUNTED Fr. 284TS-286TS
PREMIUM EFFICIENCY SEVERE DUTY

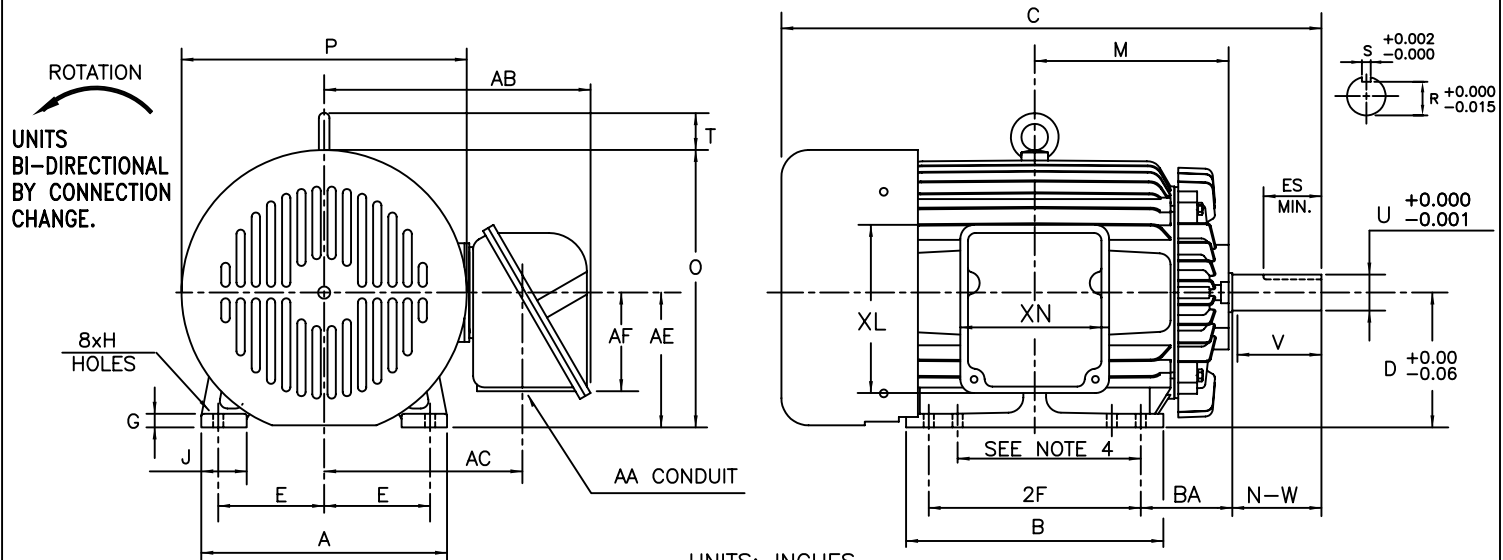

FRAME SIZE	MOUNTING				CONDUIT BOX						
	E	2F	H	BA	AA	AB	AC	AE	AF	XL	XN
284T/TS	5.50	9.50	0.53	4.75	1.50	13.8	10.3	7.00	5.1	8.7	7.7
286T/TS	5.50	11.00	0.53	4.75	1.50	13.8	10.3	7.00	5.1	8.7	7.7

FRAME SIZE	MOTOR DIMENSIONS									
	A	B	C	D	G	J	M	O	P	T
284T/286T	12.8	13.4	28.1	7.00	0.7	2.4	10.1	14.4	14.8	2.1
284TS/286TS	12.8	13.4	26.7	7.00	0.7	2.4	10.1	14.4	14.8	2.1

FRAME SIZE	SHAFT EXTENSION			KEY SEAT			BEARINGS		MAXIMUM WEIGHT
	N-W	V	U	R	S	ES	LS	OS	
284T/286T	4.62	4.38	1.875	1.591	0.500	3.28	6310C3	6310C3	471 lbs.
284TS/286TS	3.25	3.00	1.625	1.416	0.375	1.91	6310C3	6310C3	471 lbs.

- NOTES:
- DIMENSION V REPRESENTS LENGTH OF STRAIGHT PART OF SHAFT.
 - CONDUIT BOX MAY BE ROTATED IN 90° INCREMENTS AND MAY BE MOUNTED ON OPPOSITE SIDE ON SPECIAL ORDER.
 - "T" KEY DIMENSIONS EQUAL S x S x 3.25
"TS" KEY DIMENSIONS EQUAL S x S x 1.88 (MOTOR SUPPLIED WITH KEY)
 - DIMENSIONS FOR 284T MOUNTING EQUAL (2F) LOCATED IN 284T SIDE VIEW.
 - MOTOR WEIGHT SHOWN IS MAXIMUM HORSEPOWER IN FRAME.

ALL DATA SUBJECT TO CHANGE WITHOUT NOTICE.
FOR CONSTRUCTION USE ONLY CERTIFIED DATA.

CERTIFIED DATA

CUSTOMER: _____ P.O. NO.: _____ TAG NO.: _____
MOTOR MODEL NO.: _____ TOSHIBA FILE NO.: _____
HP: _____ RPM (SYN.): _____ VOLTAGE: _____ Hz: _____
FRAME SIZE: _____ LOG NO.: _____ LOG REV. LEVEL: _____
REMARKS: _____
PER: _____ ISSUE DATE: _____ SUPERSEDES: _____