

## Uninterruptible Power Systems



# XT

## 4200FA Series

### 15/25/30/50/80 KVA UPS

# 3 Year Warranty

- True On-Line, Double-Conversion UPS
- Input Power Factor > 0.99
- Input Current THD < 3%
- Wide Input Voltage Window +20% to -30%
- Wide Input Frequency Window 45 to 65 Hz
- All IGBT 12 KHz Design (Rectifier/DC Converter/Inverter)
- Electronic Power Factor Correction for 100% Generator Compatibility
- Complete Front Access for Installation, Operation, & Service
- External Battery Options for Customized Battery Back-Up Time
- XT Series Designed for Extreme Applications
- Internal Isolation Transformer(s)
- Internal Maintenance Bypass Switch\*
- 100% Unbalanced Load Capability
- SNMP/Web-Based Monitoring

# 4200FA XT 15/25/30/50/80 KVA UPS

Model Number		T42X3X150XAMXN	T42X3X250XAMXN	T42X3X300XAMXN	T42X3X500XAMXN	T42X3X800XAXXN
<b>Capacity</b>	KVA/KW	15/12	25/20	30/24	50/40	80/64
<b>Topology</b>	True On-Line, Double-Conversion, IGBT PWM, with Active Input Power Factor Correction					
<b>Input</b>	Voltage	208, 220, 240, 380, 415, 480, 600 V, Three-Phase, Three-Wire + Ground				
	Voltage Range	+10% to -30%; +20% to -30% Online (Without Utilizing Battery)				
	Power Factor	Greater than 0.99				
	Current THD	Less than 3%				
	Frequency	50/60 Hz (Range 45 to 65 Hz)				
	Current Limit	115% Maximum				
<b>Output</b>	Voltage	208, 220, 240, 380, 415, 480, 600 V, Three-Phase, Four-Wire + Ground				
	Frequency	50/60 Hz $\pm$ 0.01% (Can be Used as Frequency Converter)				
	Voltage Regulation	< 1% Balanced, 100% Load Step; < 2% Unbalanced, 100% Load Step				
	Overload (inverter)	125% for 90 Seconds; 150% for 30 Seconds				
	Overload (bypass)	125% for 10 Minutes; 1000% for 10 ms				
<b>Battery</b>	DC Link	288 VDC				
	Ripple Voltage	<0.5% DC				
<b>Environment</b>	Temperature Range	0° to 40°C Operating / -20° to +50°C Storage				
	Relative Humidity	0 to 95% Non-Condensing				
	Heat Rejection	13,648 BTUs	20,384 BTUs	24,461 BTUs	32,015 BTUs	41,595 BTUs
	Efficiency	75% AC-AC 82% DC-AC	77% AC-AC 83% DC-AC	77% AC-AC 83% DC-AC	81% AC-AC 85% DC-AC	84% AC-AC 83% DC-AC
<b>Dimensions</b>	Dimensions (L x D x H)	20" x 36.3" x 59.7"			35.5" x 38.3" x 59.3"	41" x 31" x 74"
<b>Transformer(s) (1/2)</b>	UPS Weight (lbs.)	788/988	793/998	803/1003	1581/1941	2200
	Altitude	6600 ft. (2000 m) (Maximum Without Derating)				
	Audible Noise	< 60 DBA at 1 m			< 65 DBA at 1 m	< 65 DBA at 1 m
<b>Features</b>	Internal Make-Before-Break Maintenance Bypass Switch*, RS232, & Dry Contact Interface					
<b>Options</b>	Dual-Input Feed, Air Filters for Door, RemotEyell®					
<b>Standards</b>	UL 1778, cUL, NEC, ISO9001, ISO14001, ANSI C62.41 (IEEE 587), NEMA PE1-1993					
<b>Warranty</b>	See Toshiba Warranty Policy for Full Details					
<b>Service</b>	7 x 24 Technical Support 1-877-867-8773					

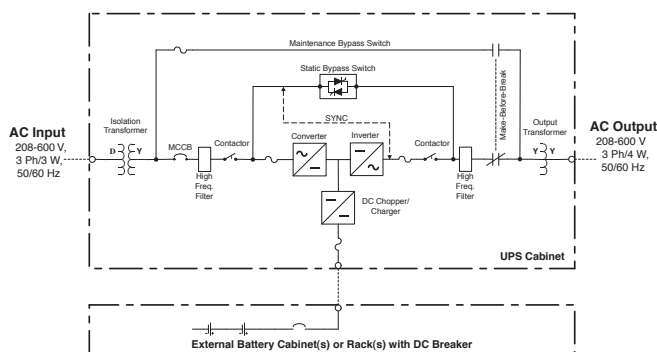

**UPS    ADJUSTABLE SPEED DRIVES    MOTORS    CONTROLS    INSTRUMENTATION    PLC**

# TOSHIBA

TOSHIBA INTERNATIONAL CORPORATION

**INDUSTRIAL DIVISION**

13131 West Little York Road, Houston, Texas 77041

Tel 713/466-0277 Fax 713/466-8773

US 800/231-1412 Canada 800/872-2192 Mexico 001/800/527-1204

www.toshiba.com/ind

Copyright 5/2010

Available Through:

