

Owner's Manual

8, 10, 14, 17 & 20kW Air-cooled,
Automatic Standby Generators

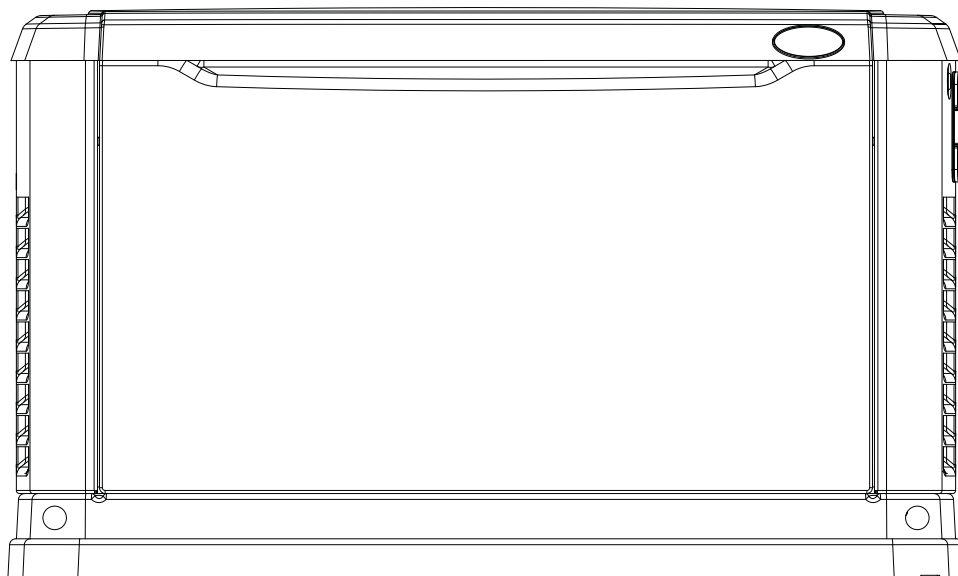

DO NOT LIFT UNIT BY ROOF!



Not intended for use as Primary Power in place of utility
or in life-support applications.



—  **DANGER**  —

DEADLY EXHAUST FUMES. OUTDOOR INSTALLATION ONLY!

INTRODUCTION

Thank you for purchasing this compact, high performance, air-cooled, engine-driven generator. It is designed to automatically supply electrical power to operate critical loads during a utility power failure.

This unit is factory installed in an all-weather, metal enclosure that **is intended exclusively for outdoor installation**. This generator will operate using either vapor withdrawn liquid propane (LP) or natural gas (NG).

NOTE:

This generator is suitable for supplying typical residential loads such as Induction Motors (sump pumps, refrigerators, air conditioners, furnaces, etc.), Electronic Components (computer, monitor, TV, etc.), Lighting Loads and Microwaves.

◆ READ THIS MANUAL THOROUGHLY

If any portion of this manual is not understood, contact the nearest Dealer for starting, operating and servicing procedures.

Throughout this publication, and on tags and decals affixed to the generator, DANGER, WARNING, CAUTION and NOTE blocks are used to alert personnel to special instructions about a particular operation that may be hazardous if performed incorrectly or carelessly. Observe them carefully. Their definitions are as follows:

—▲ DANGER ▲—

After this heading, read instructions that, if not strictly complied with, will result in serious personal injury, including death, in addition to property damage.

—▲ WARNING ▲—

After this heading, read instructions that, if not strictly complied with, may result in serious personal injury or property damage.

—▲ CAUTION ▲—

After this heading, read instructions that, if not strictly complied with, could result in damage to equipment and/or property.

NOTE:

After this heading, read explanatory statements that require special emphasis.

These safety warnings cannot eliminate the hazards that they indicate. Common sense and strict compliance with the special instructions while performing the service are essential to preventing accidents.

Four commonly used safety symbols accompany the DANGER, WARNING and CAUTION blocks. The type of information each indicates follows:

 This symbol points out important safety information that, if not followed, could endanger personal safety and/or property of others.

 This symbol points out potential explosion hazard.

 This symbol points out potential fire hazard.

 This symbol points out potential electrical shock hazard.

The operator is responsible for proper and safe use of the equipment. The manufacturer strongly recommends that the operator read this *Owner's Manual* and thoroughly understand all instructions before using this equipment. The manufacturer also strongly recommends instructing other users to properly start and operate the unit. This prepares them if they need to operate the equipment in an emergency.

◆ CONTENTS

This manual contains pertinent owner's information for these models:

- 7 kW NG, 8 kW LP, single-cylinder GH-410 Engine
- 9 kW NG, 10 kW LP, V-twin GT-530 Engine
- 13 kW NG, 14 kW LP, V-twin GT-990 Engine
- 16 kW NG, 17 kW LP, V-twin GT-990 Engine
- 18 kW NG, 20 kW LP, V-twin GT-999 Engine

◆ OPERATION AND MAINTENANCE

It is the operator's responsibility to perform all safety checks, to make sure that all maintenance for safe operation is performed promptly, and to have the equipment checked periodically by a Dealer. Normal maintenance service and replacement of parts are the responsibility of the owner/operator and, as such, are not considered defects in materials or workmanship within the terms of the warranty. Individual operating habits and usage contribute to the need for maintenance service.

Proper maintenance and care of the generator ensures a minimum number of problems and keep operating expenses at a minimum. See a Dealer for service aids and accessories.

◆ HOW TO OBTAIN SERVICE

When the generator requires servicing or repairs, contact a Dealer for assistance. Service technicians are factory-trained and are capable of handling all service needs.

When contacting a Dealer about parts and service, always supply the complete model number and serial number of the unit as given on its data decal, which is located on the generator. See section "The Generator" for decal location.

Model No. _____ Serial No. _____

Introduction Inside Front Cover

Read This Manual Thoroughly.....IFC
ContentsIFC
Operation and Maintenance.....IFC
How to Obtain ServiceIFC

Table of Contents 1

Safety Rules..... 2

Standards Index.....3

Section 1 – General Information 4

1.1 Unpacking/Inspection4
1.2 Protection Systems4
1.3 NEC Requirement for Arc Fault Circuit
Interruption Breaker for Bedrooms4
1.4 Emission Information.....5
1.5 The Generator6
1.6 Specifications7
1.7 System Set LED8
1.8 Fuel Requirements and Recommendations.....8
1.9 Fuel Consumption8
1.10 Reconfiguring the Fuel System.....9
1.11 Location.....10
1.12 Battery Requirements13
1.13 Battery Installation.....13
1.14 The Battery13
1.15 Battery Charger14

**Section 2 – Post Installation Start-up
and Adjustments 14**

2.1 Before Initial Startup.....14
2.2 Electrical Checks14
2.3 Generator Tests Under Load.....15
2.4 Checking Automatic Operation.....15
2.5 Engine Governor Adjustment16
2.6 Voltage Regulator Adjustment16

Section 3 – Operation..... 17

3.1 Control Panel Interface17
3.2 Automatic Transfer Operation.....18
3.3 Sequence of Automatic Operation18
3.4 Manual Transfer Operation19
3.5 Side Compartment (V-twin Only)20
3.6 Protection Systems21

Section 4 – Maintenance 22

4.1 Fuse.....22
4.2 Checking the Engine Oil Level22
4.3 Changing the Engine Oil.....23
4.4 Changing the Engine Air Cleaner24
4.5 Spark Plug(s)25
4.6 Battery Maintenance.....25
4.7 Adjusting GH-410/GT-530/990/999 Valve Clearance25
4.8 Cooling System.....26
4.9 Attention After Submersion.....27
4.10 Corrosion Protection.....27
4.11 Out of Service Procedure.....27
4.12 Service Schedule28

Section 5 – Troubleshooting 29

5.1 Troubleshooting Guide29



Section 6 – Appendix 30

6.1 Menu System Navigation30

Section 7 – Installation Diagrams 32

Section 8 – Warranty 36



 **SAVE THESE INSTRUCTIONS** – The manufacturer suggests that these rules for safe operation be copied and posted near the unit's installation site. Safety should be stressed to all operators and potential operators of this equipment. 

**WARNING:**

The engine exhaust from this product contains chemicals known to the state of California to cause cancer, birth defects or other reproductive harm.

**WARNING:**

This product contains or emits chemicals known to the state of California to cause cancer, birth defects or other reproductive harm.

Study these SAFETY RULES carefully before installing, operating or servicing this equipment. Become familiar with this *Owner's Manual* and with the unit. The generator can operate safely, efficiently and reliably only if it is properly installed, operated and maintained. Many accidents are caused by failing to follow simple and fundamental rules or precautions.

The manufacturer cannot anticipate every possible circumstance that might involve a hazard. The warnings in this manual, and on tags and decals affixed to the unit are, therefore, not all-inclusive. If using a procedure, work method or operating technique the manufacturer does not specifically recommend, ensure that it is safe for others. Also make sure the procedure, work method or operating technique utilized does not render the generator unsafe.

—  **DANGER**  —

 **Despite the safe design of this generator, operating this equipment imprudently, neglecting its maintenance or being careless can cause possible injury or death. Permit only responsible and capable persons to install, operate and maintain this equipment.**

 **Potentially lethal voltages are generated by these machines. Ensure all steps are taken to render the machine safe before attempting to work on the generator.**

 **Parts of the generator are rotating and/or hot during operation. Exercise care near running generators.**

 **Installation must always comply with applicable codes, standards, laws and regulations.**

 **A running generator gives off carbon monoxide, and odorless, colorless poison gas. Breathing in carbon monoxide can cause headaches, fatigue, dizziness, nausea, vomiting, confusion, fainting, seizures or death.**

 **GENERAL HAZARDS** 

- For safety reasons, the manufacturer recommends that this equipment be installed, serviced and repaired by a Service Dealer or other competent, qualified electrician or installation technician who is familiar with applicable codes, standards and regulations. The operator also must comply with all such codes, standards and regulations.
- The engine exhaust fumes contain carbon monoxide, which can be DEADLY. This dangerous gas, if breathed in sufficient concentrations, can cause unconsciousness or even death. Do NOT alter or add to the exhaust system or do anything that might render the system unsafe or in noncompliance with applicable codes and standards.
- Install a battery operated carbon monoxide alarm indoors, according to manufacturer's instructions/recommendations.
- Adequate, unobstructed flow of cooling and ventilating air is critical to correct generator operation. Do not alter the installation or permit even partial blockage of ventilation provisions, as this can seriously affect safe operation of the generator. **The generator MUST be installed and operated outdoors only.**
- Keep hands, feet, clothing, etc., away from drive belts, fans, and other moving or hot parts. Never remove any drive belt or fan guard while the unit is operating.
- When working on this equipment, remain alert at all times. Never work on the equipment when physically or mentally fatigued.
- Inspect the generator regularly, and contact the nearest Dealer for parts needing repair or replacement.
- Before performing any maintenance on the generator, disconnect its battery cables to prevent accidental start up. Disconnect the cable from the battery post indicated by a NEGATIVE, NEG or (–) first, then remove the POSITIVE, POS or (+) cable. When reconnecting the cables, connect the POSITIVE cable first, the NEGATIVE cable last.
- Never use the generator or any of its parts as a step. Stepping on the unit can stress and break parts, and may result in dangerous operating conditions from leaking exhaust gases, fuel leakage, oil leakage, etc.

 **ENGINE EXHAUST HAZARDS** 

- Generator engine exhaust contains DEADLY carbon monoxide, an odorless, colorless poisonous gas. Breathing carbon monoxide can cause: dizziness, throbbing temples, nausea, muscular twitching, headache, vomiting, weakness and sleepiness, inability to think clearly, fainting, unconsciousness or even death. If you experience any carbon monoxide poisoning symptoms, move into fresh air and immediately seek medical attention.
- Never operate the generator set with the vehicle inside any garage or other enclosed area.



 **ELECTRICAL HAZARDS** 

- All generators covered by this manual produce dangerous electrical voltages and can cause fatal electrical shock. Utility power delivers extremely high and dangerous voltages to the transfer switch as does the standby generator when it is in operation. Avoid contact with bare wires, terminals, connections, etc., while the unit is running. Ensure all appropriate covers, guards and barriers are in place, secured and/or locked before operating the generator. If work must be done around an operating unit, stand on an insulated, dry surface to reduce shock hazard.
- Do not handle any kind of electrical device while standing in water, while barefoot, or while hands or feet are wet. DANGEROUS ELECTRICAL SHOCK MAY RESULT.
- The National Electrical Code (NEC) requires the frame and external electrically conductive parts of the generator to be connected to an approved earth ground. Local electrical codes also may require proper grounding of the generator electrical system.
- After installing this home standby electrical system, the generator may crank and start at any time without warning. When this occurs, load circuits are transferred to the STANDBY (generator) power source. To prevent possible injury if such a start and transfer occur, always set the generator's AUTO/OFF/MANUAL switch to its OFF position before working on equipment and remove the 15A fuse from the generator control panel.
- In case of accident caused by electric shock, immediately shut down the source of electrical power. If this is not possible, attempt to free the victim from the live conductor. AVOID DIRECT CONTACT WITH THE VICTIM. Use a nonconducting implement, such as a dry rope or board, to free the victim from the live conductor. If the victim is unconscious, apply first aid and get immediate medical help.
- Never wear jewelry when working on this equipment. Jewelry can conduct electricity resulting in electric shock, or may get caught in moving components causing injury.

 **FIRE HAZARDS** 

- For fire safety, the generator must be installed and maintained properly. **Installation must always comply with applicable codes, standards, laws and regulations.** Adhere strictly to local, state and national electrical and building codes. Comply with regulations the Occupational Safety and Health Administration (OSHA) has established. Also, ensure that the generator is installed in accordance with the manufacturer's instructions and recommendations. Following proper installation, do nothing that might alter a safe installation and render the unit in noncompliance with the aforementioned codes, standards, laws and regulations.
- Keep a fire extinguisher near the generator at all times. Extinguishers rated "ABC" by the National Fire Protection Association are appropriate for use on the standby electric system. Keep the extinguisher properly charged and be familiar with its use. Consult the local fire department with any questions pertaining to fire extinguishers.

 **EXPLOSION HAZARDS** 

- Do not smoke around the generator. Wipe up any fuel or oil spills immediately. Ensure that no combustible materials are left in the generator compartment, or on or near the generator, as FIRE or EXPLOSION may result. Keep the area surrounding the generator clean and free from debris.
- Gaseous fluids such as natural gas and liquid propane (LP) gas are extremely EXPLOSIVE. Install the fuel supply system according to applicable fuel-gas codes. Before placing the home standby electric system into service, fuel system lines must be properly purged and leak tested according to applicable code. After installation, inspect the fuel system periodically for leaks. No leakage is permitted.

◆ STANDARDS INDEX

In the absence of pertinent standards, codes, regulations and laws, the published information listed below may be used for installation guidance for this equipment.

1. NFPA No. 37, STATIONARY COMBUSTION ENGINES AND GAS TURBINES, available from the National Fire Protection Association, 470 Atlantic Avenue, Boston, MA 02210.
2. NFPA No. 76A, ESSENTIAL ELECTRICAL SYSTEMS FOR HEALTH CARE FACILITIES, available same as Item 1.
3. NFPA No. 54, NATIONAL FUEL GAS CODE, available same as Item 1.
4. NFPA No. 58, AMERICAN NATIONAL STANDARD FOR STORAGE AND HANDLING OF LIQUEFIED PETROLEUM GAS, available same as Item 1.
5. NFPA No. 70, NFPA HANDBOOK OF NATIONAL ELECTRIC CODE, available same as Item 1.
6. Article X, NATIONAL BUILDING CODE, available from the American Insurance Association, 85 John Street, New York, N.Y. 10038.
7. AGRICULTURAL WIRING HANDBOOK, available from the Food and Energy Council, 909 University Avenue, Columbia, MO 65201.
8. ASAE EP-3634, INSTALLATION AND MAINTENANCE OF FARM STANDBY ELECTRICAL SYSTEMS, available from the American Society of Agricultural Engineers, 2950 Niles Road, St. Joseph, MI 49085.
9. NFPA No. 30, FLAMMABLE AND COMBUSTIBLE LIQUIDS CODE, available same as Item 1.

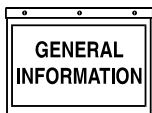

⚠ DANGER ⚠

⚠ Only qualified electricians or contractors should attempt such installations, which must comply strictly with applicable codes, standards and regulations.

1.1 UNPACKING/INSPECTION

After unpacking, carefully inspect the contents for damage.

- This standby generator set is ready for installation with a factory supplied and pre-mounted base pad and has a weather protective enclosure that is intended for **outdoor installation only**.

⚠ WARNING ⚠

⚠ If this generator is used to power electrical load circuits normally powered by a utility power source, it is required by code to install a transfer switch. The transfer switch must effectively isolate the electrical system from the utility distribution system when the generator is operating (NEC 700, 701 & 702). Failure to isolate an electrical system by such means will result in damage to the generator and also may result in injury or death to utility power workers due to backfeed of electrical energy.

If any loss or damage is noted at time of delivery, have the person(s) making the delivery note all damage on the freight bill or affix their signature under the consignor's memo of loss or damage.

If a loss or damage is noted after delivery, separate the damaged materials and contact the carrier for claim procedures.

"Concealed damage" is understood to mean damage to the contents of a package that is not in evidence at the time of delivery, but is discovered later.

To properly open the roof, press down on the center top lip and release the latch. If pressure is not applied from the top, the roof may appear stuck. Always verify that the side lock is unlocked before attempting to lift the roof.

1.2 PROTECTION SYSTEMS

Unlike an automobile engine, the generator may have to run for long periods of time with no operator present to monitor engine conditions. For that reason, the engine is equipped with the following systems that protect it against potentially damaging conditions:

1. Low Oil Pressure Sensor
2. High Temperature Sensor
3. Overcrank
4. Overspeed
5. RPM Sensor
6. Low Battery

There are readouts on the control panel to notify personnel that one of these failures has occurred. There is also a System Set LED (single cylinder) or a Status message on the display (V-twins) that displays when all of the conditions described in the "System Set LED" section are true.

1.3 NEC REQUIREMENT FOR ARC FAULT CIRCUIT INTERRUPTION BREAKER FOR BEDROOMS

In 2001, the National Electric Code (NEC) introduced a requirement for new construction. This new requirement indicates the need for Arc Fault Circuit Interrupters to be used to protect the complete branch circuit that feeds a dwelling bedroom. The actual NEC requirement is indicated below.

◆ 1.3.1 SECTION 210.12 ARC FAULT CIRCUIT INTERRUPTER PROTECTION

1. Definition: An arc fault circuit interrupter is a device intended to provide protection from the effects of arc faults by recognizing characteristics unique to arcing and by functioning to de-energize the circuit when an arc fault is detected.
2. Dwelling Unit Bedrooms: All branch circuits that supply 125 volt, single-phase, 15 and 20 ampere outlets installed in dwelling unit bedrooms shall be protected by an arc fault circuit interrupter listed to provide protection of the entire branch circuit.

Section 210.12 requires that AFCI protection be provided on branch circuits that supply outlets (receptacle, lighting, etc.) in dwelling bedrooms. The requirement is limited to 15 and 20 ampere, 125 volt circuits. There is no prohibition against providing AFCI protection on other circuits or in locations other than bedrooms. Because circuits are often shared between a bedroom and other areas such as closets and hallways, providing AFCI protection on the complete circuit would comply with 210.12.

If during the installation of the home standby system the decision is made to provide back up power to a bedroom branch circuit, then the circuit breaker in the transfer switch should be replaced with an Arc Fault Circuit Interrupter.

It is most important that breakers only be switched like for like. For instance, if replacing a 15A breaker, it MUST be replaced with a 15A AFCI breaker. Likewise, a 20A breaker MUST be replaced with a 20A AFCI.

These AFCI breakers are available at the nearest hardware store.

Eaton Cat #	Description
BR115AF	1" 15A Single Pole AFCI
CH115AF	3/4" 15A Single Pole AFCI
BR120AF	1" 20A Single Pole AFCI
CH120AF	3/4" 20A Single Pole AFCI

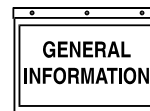

1.4 EMISSION INFORMATION

The Environmental Protection Agency requires that this generator complies with exhaust emission standards. This generator is certified to meet the applicable EPA emission levels. Additional information regarding the requirements set by the EPA is as follows:

The generator is certified for use as a stationary engine for standby power generation. Any other use may be a violation of federal and/or local laws. It is important that to follow the maintenance specifications in the "Maintenance" section to ensure that the engine complies with the applicable emission standards for the duration of the engine's life. This engine is certified to operate on Liquid Propane fuel and pipeline Natural Gas. The emission control system on the generator consists of the following:

- Fuel Metering System
 - Carburetor/mixer assembly
 - Fuel regulator
- Air Induction System
 - Intake pipe/manifold
 - Air cleaner
- Ignition System
 - Spark plug
 - Ignition module

The Emissions Compliance Period referred to on the Emissions Compliance Label indicates the number of operating hours for which the engine has been shown to meet Federal emission requirements. See the table below to determine the compliance period for the generator. The displacement of the generator is listed on the Emissions Compliance Label.

Displacement	Category	Compliance Period
< 66 cc	A	300 Hours
	B	125 Hours
	C	50 Hours
≥ 66 cc - < 225 cc	A	500 Hours
	B	250 Hours
	C	125 Hours
≥ 225 cc	A	1000 Hours
	B	500 Hours
	C	250 Hours

1.5 THE GENERATOR

Figure 1.1 – 8kW, Single Cylinder, GH-410 Engine (door removed)

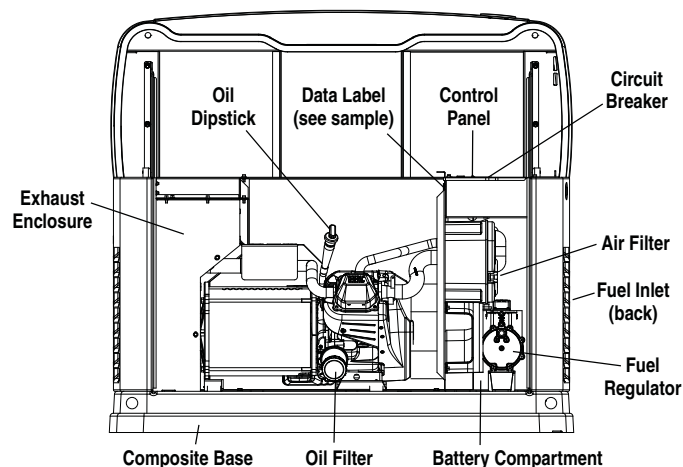

Figure 1.2 – 10kW, V-twin, GT-530 Engine (door removed)

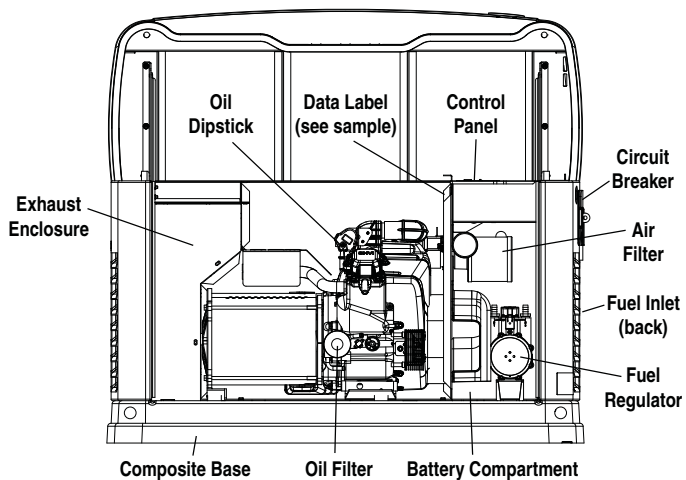
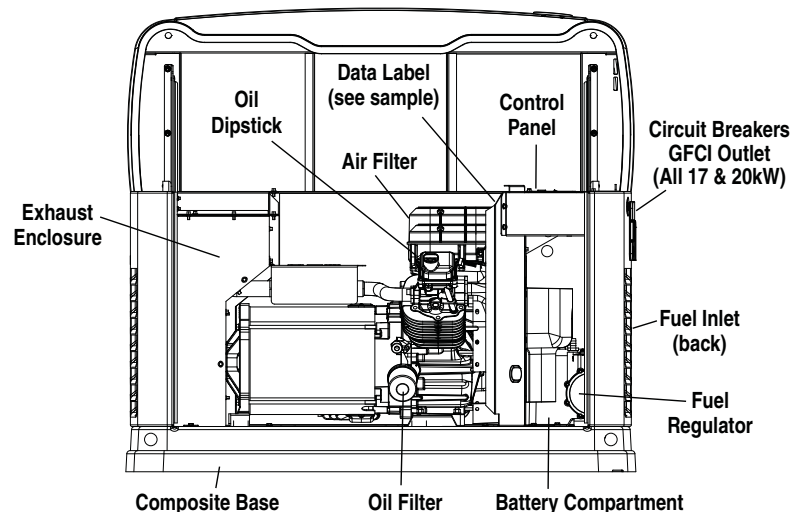

Figure 1.3 – 14, 17 and 20kW, V-twin, GT-990/GT-999 Engine (door removed)



Data Label Sample

MODEL	<input type="text"/>
SERIAL	<input type="text"/>
VOLTS	<input type="text"/>
AMPS	<input type="text"/>
1 PH, 60 Hz, RPM 3600	
RAINPROOF ENCLOSURE FITTED	
CLASS H INSULATION	
RATED AMBIENT TEMP – 25°C	
FOR STANDBY SERVICE	
NEUTRAL FLOATING	
MAX LOAD UNBALANCE–50%	
WHITEWATER, WIS	
MADE IN U.S.A.	

1.6 SPECIFICATIONS

◆ 1.6.1 GENERATOR

Model	8kW	10kW	14kW	17kW	20kW
Rated Maximum Power Capacity (Watts*)	7,000 NG 8,000 LP	9,000 NG 10,000 LP	13,000 NG 14,000 LP	16,000 NG 17,000 LP	18,000 NG 20,000 LP
Rated Voltage	120/240				
Rated Maximum Load Current (Amps)					
120 Volts** (NG/LP)	58.3/66.6	75.0/83.3	108.3/116.6	133.3/141.6	150.0/166.6
240 Volts (NG/LP)	29.2/33.3	37.5/41.6	54.2/58.3	66.6/70.8	75.0/83.3
Main Circuit Breaker	35 Amp	45 Amp	60 Amp	65 Amp	100 Amp
Phase	1				
Number of Rotor Poles	2				
Rated AC Frequency	60 Hz				
Battery Requirement	Group 26R, 12 Volts and 350 CCA Minimum	Group 26R, 12 Volts and 525 CCA Minimum			
Weight (unit only in lbs.)	340	387	439	455/421	450
Enclosure	Steel	Steel	Steel	Steel/Aluminum	Aluminum
Normal Operating Range	-20° F (-28.8° C) to 77° F (25° C)				
* Maximum wattage and current are subject to and limited by such factors as fuel Btu content, ambient temperature, altitude, engine power and condition, etc. Maximum power decreases about 3.5 percent for each 1,000 feet above sea level; and also will decrease about 1 percent for each 6 C (10 F) above 16 C (60 F) ambient temperature.					
** Load current values shown for 120 volts are maximum TOTAL values for two separate circuits. The maximum current in each circuit must not exceed the value stated for the 240 volts.					
*** Circuits to be moved must be protected by same size breaker. For example, a 15 amp circuit in the main panel must be a 15 amp circuit in the transfer switch.					

◆ 1.6.2 ENGINE

Model	8 kW	10 kW	14/17 kW	20 kW
Type of Engine	GH-410	GT-530	GT-990	GT-999
Number of Cylinders	1	2	2	2
Rated Horsepower @ 3,600 rpm	14.8	18	32	36
Displacement	410cc	530cc	992cc	999cc
Cylinder Block	Aluminum w/Cast Iron Sleeve			
Valve Arrangement	Overhead Valves			
Ignition System	Solid-state w/Magneto			
Recommended Spark Plug	RC14YC	BPR6HS	RC14YC	RC12YC
Spark Plug Gap	0.76 mm (0.030 inch)	0.76 mm (0.030 inch)	1.02 mm (0.040 inch)	0.76 mm (0.030 inch)
Compression Ratio	8.6:1	9.5:1	9.5:1	9.5:1
Starter	12 VDC			
Oil Capacity Including Filter	Approx. 1.5 Qts	Approx. 1.7 Qts	Approx. 1.7 Qts	Approx. 1.7 Qts
Recommended Oil Filter	Part # 070185F			
Recommended Air Filter	Part # 0G3332	Part # 0E9581	Part # 0C8127	Part # 0G5894
Operating RPM	3,600			

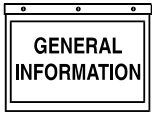

1.7 SYSTEM SET LED

The "System Set" LED (single cylinder) or "Ready to Run" on the display (v-twin) is ready when all of the following conditions are true:

1. The AUTO/OFF/MANUAL switch is set to the AUTO position.
2. The utility voltage being supplied to the unit is being sensed by the PCB. If the utility sense voltage is not connected to the unit or if it is below approximately 150-160 volts AC, then the system set light will flash rapidly (8kW). This indicates that if the AUTO/OFF/MANUAL switch is placed in the Auto position, the generator will start.
3. No alarms are present, for example, low oil pressure, high temperature, etc.

1.8 FUEL REQUIREMENTS AND RECOMMENDATIONS

With LP gas, use only the vapor withdrawal system. This type of system uses the vapors formed above the liquid fuel in the storage tank.

The engine has been fitted with a fuel carburetion system that meets the specifications of the 1997 California Air Resources Board for tamper-proof dual fuel systems. The unit will run on natural gas or LP gas, but it has been factory set to run on natural gas. Should the primary fuel need to be changed to LP gas, the fuel system needs to be reconfigured. See the reconfiguring the Fuel System section for instructions on reconfiguration of the fuel system.

Recommended fuels should have a Btu content of at least 1,000 Btus per cubic foot for natural gas; or at least 2,520 Btus per cubic foot for LP gas. Ask the fuel supplier for the Btu content of the fuel.

Required fuel pressure for natural gas is five (5) inches to seven (7) inches water column (0.18 to 0.25 psi); and for liquid propane, 10 inches to 12 inches of water column (0.36 to 0.43 psi). The primary regulator for the propane supply is NOT INCLUDED with the generator.

NOTE:

All pipe sizing, construction and layout must comply with NFPA 54 for natural gas applications and NFPA 58 for liquid propane applications. Once the generator is installed, verify that the fuel pressure NEVER drops below four (4) inches water column for natural gas or 10 inches water column for liquid propane.

Prior to installation of the generator, the installer should consult local fuel suppliers or the fire marshal to check codes and regulations for proper installation. Local codes will mandate correct routing of gaseous fuel line piping around gardens, shrubs and other landscaping to prevent any damage.

Special considerations should be given when installing the unit where local conditions include flooding, tornados, hurricanes, earthquakes and unstable ground for the flexibility and strength of piping and their connections.

Use an approved pipe sealant or joint compound on all threaded fitting.

All installed gaseous fuel piping must be purged and leak tested prior to initial start-up in accordance with local codes, standards and regulations.

1.9 FUEL CONSUMPTION

Unit	Nat. Gas		LP Vapor	
	1/2 Load	Full Load	1/2 Load	Full Load
7/8 kW	77	140	0.94/34	1.68/62
9/10 kW	102	156	1.25/46	1.93/70
13/14 kW	156	220	1.56/58	2.30/84
16/17 kW	183	261	1.61/59	2.57/94
18/20 kW	206	294	1.89/69	2.90/106

* Natural gas is in cubic feet per hour.
** LP is in gallons per hour/cubic feet per hour.
*** Values given are approximate.

Verify that gas meter is capable of providing enough fuel flow to include household appliances.

◆ 1.9.1 BTU FLOW REQUIREMENTS - NATURAL GAS

BTU flow required for each unit based on 1000 BTU per cubic foot.

- 7kW — 140,000 BTU/Hour
- 9kW — 156,000 BTU/Hour
- 13kW — 220,000 BTU/Hour
- 18kW — 294,000 BTU/Hour



⚠ Gaseous fuels such as natural gas and liquid propane (LP) gas are highly explosive. Even the slightest spark can ignite such fuels and cause an explosion. No leakage of fuel is permitted. Natural gas, which is lighter than air, tends to collect in high areas. LP gas is heavier than air and tends to settle in low areas.

NOTE:

A minimum of one approved manual shut-off valve must be installed in the gaseous fuel supply line. The valve must be easily accessible. Local codes determine the proper location.

1.10 RECONFIGURING THE FUEL SYSTEM

◆ 1.10.1 8 KW, 410CC ENGINE

To reconfigure the fuel system from NG to LP, follow these steps (Figure 1.4):

NOTE:

The primary regulator for the propane supply is **NOT INCLUDED** with the generator. A fuel pressure of 10 to 12 inches of water column (0.36 to 0.43 psi) to the fuel inlet of the generator **MUST BE SUPPLIED**.

1. Turn off the main gas supply (if connected).
2. Open the roof and remove the door.
3. Remove the battery (if installed).
4. Take the plastic T-handle fuel selector in the poly bag supplied with the generator.
5. Locate the selector knob on the air box cover, behind the yellow air filter door and power bulge. The unit comes from the factory in the NG (Natural Gas) position. Grasping the T-handle, insert the pin end into the hole in the selector knob and pull out to overcome spring pressure and then twist clockwise 90 degrees and allow the selector to return in once aligned with the LP (Liquid Propane) position.
6. Save this tool with the Owner's Manual.
7. Install the battery, door and close the roof.
8. Reverse the procedure to convert back to natural gas.

Figure 1.4 – Fuel Selector



NOTE:

Use an approved pipe sealant or joint compound on all threaded fittings to reduce the possibility of leakage.

◆ 1.10.2 10, 14, 17 AND 20KW, V-TWIN ENGINES

To reconfigure the fuel system from NG to LP, follow these steps:

NOTE:

The primary regulator for the propane supply is **NOT INCLUDED** with the generator. A fuel pressure of 10 to 12 inches of water column (0.36 to 0.43 psi) to the fuel inlet of the generator **MUST BE SUPPLIED**.

1. Open the roof.
 2. For 10kW units: Loosen clamp and slide back the air inlet hose.
 - Slide fuel selector on carburetor out towards the back of the enclosure (Figures 1.5 and 1.6).
 - Return the inlet hose and tighten clamp securely.
- For 14, 17 and 20kW units:** remove the air cleaner cover.
- Slide the selector lever out towards the back of the enclosure (Figures 1.7 and 1.8).
 - Return the air cleaner cover and tighten the two thumb screws.

Figure 1.5 - 10kW, GT-530 (Inlet Hose Slid Back)

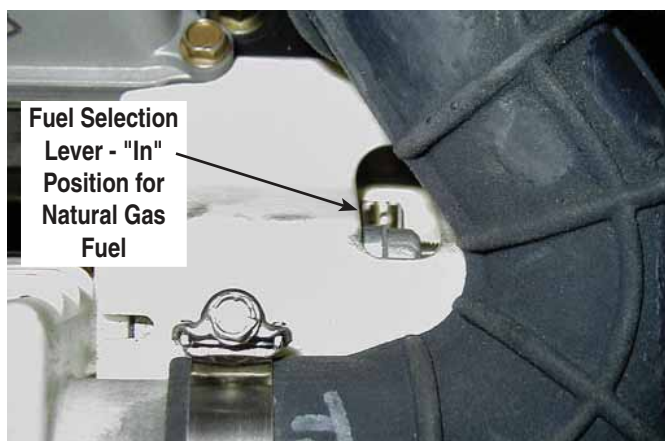
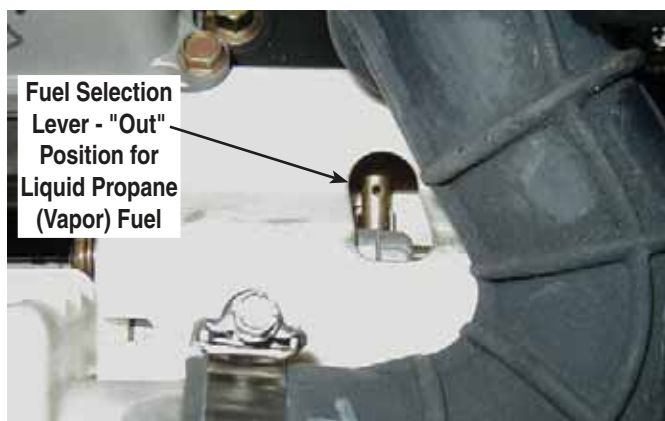

Figure 1.6 - 10kW, GT-530 (Inlet Hose Slid Back)



3. Close the roof.
4. Reverse the procedure to convert back to natural gas.

**Figure 1.7 - 14, 17, & 20kW,
GT-990/GT-999 (Airbox Cover Removed)**



**Figure 1.8 - 14, 17, & 20kW,
GT-990/GT-999 (Airbox Cover Removed)**



1.11 LOCATION

◆ 1.11.1 GENERATOR

Install the generator set, in its protective enclosure, **outdoors**, where adequate cooling and ventilating air is always available (Figure 1.9). Consider these factors:

- The installation of the generator **must comply strictly with NFPA 37, NFPA 54, NFPA 58, and NFPA 70 standards.**
- Install the unit where air inlet and outlet openings will not become obstructed by leaves, grass, snow, etc.. If prevailing winds will cause blowing or drifting, consider using a wind-break to protect the unit.
- Install the generator on high ground where water levels will not rise and endanger it.

- Allow sufficient room on all sides of the generator for maintenance and servicing. This unit must be installed in accordance with current applicable NFPA 37 and NFPA 70 standards; as well as any other federal, state and local codes for minimum distances from other structures. **DO NOT** install under wooden decks or structures unless there is at least four (4) feet of clearance above the generator, three (3) feet of clearance on sides and front, and 18 inches of clearance at back of unit.
- Install the unit where rain gutter down spouts, roof run-off, landscape irrigation, water sprinklers or sump pump discharge does not flood the unit or spray the enclosure, including any air inlet or outlet openings.
- Install the unit where services will not be affected or obstructed, including concealed, underground or covered services such as electrical, fuel, phone, air conditioning or irrigation.
- Where strong prevailing winds blow from one direction, face the generator air inlet openings to the prevailing winds.

Figure 1.9 – Generator Clearances

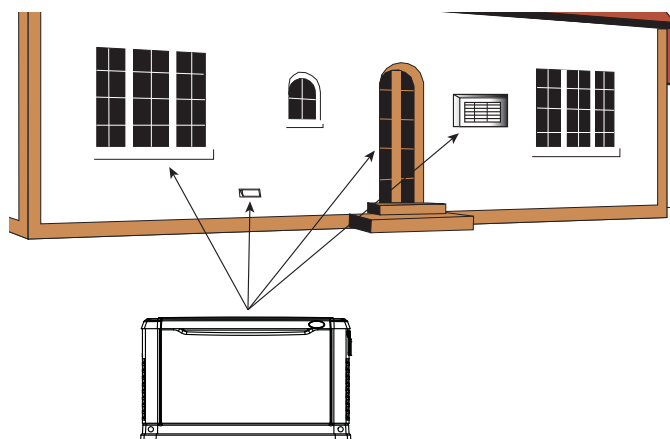

- Install the generator as close as possible to the fuel supply, to reduce the length of piping.
- Install the generator as close as possible to the transfer switch. **REMEMBER THAT LAWS OR CODES MAY REGULATE THE DISTANCE AND LOCATION.**
- The genset must be installed on a level surface. The base frame must be level within two (2) inches all around.
- The generator is typically placed on pea gravel or crushed stone. Check local codes if a concrete slab is required. If a concrete base slab is required, all federal, state and local codes should be followed. Special attention should be given to the concrete base slab which should exceed the length and width of the generator by a minimum of six (6) inches (0.152 meters) on all sides.

—  **DANGER**  —

 The engine exhaust fumes contain carbon monoxide, which can be **DEADLY**. This dangerous gas, if breathed in sufficient concentrations, can cause unconsciousness or even death. This generator must be installed properly, in strict compliance with applicable codes and standards. Following installation, do nothing that might render the system unsafe or in noncompliance with such codes and standards.

- Operate the generator outdoors **ONLY**.
- Keep exhaust gases from entering a confined area through windows, doors, ventilation, crawl spaces or other openings (Figure 1.9).
- Generac Power Systems as a responsible manufacturer highly recommends that carbon monoxide detector(s) be installed indoors according to the manufacturer's instructions/recommendations.
- The generator must be mounted safely per applicable codes and the manufacturer's specifications. Do **NOT** alter or add to the exhaust system, or do anything that might render the exhaust system unsafe or in noncompliance with applicable codes and standards.

◆ **1.11.2 INSTALLATION GUIDELINES FOR EATON STATIONARY AIR-COOLED 8, 10, 14, 17 AND 20 KW GENERATORS.**

The National Fire Protection Association has a standard for the installation and use of stationary combustion engines. That standard is NFPA 37 and its requirements limit the spacing of an enclosed generator set from a structure or wall (Figure 1.10).

NFPA 37, Section 4.1.4, Engines Located Outdoors. Engines, and their weatherproof housings if provided, that are installed outdoors shall be located at least 5 ft. from openings in walls and at least 5 ft. from structures having combustible walls. A minimum separation shall not be required where the following conditions exist:

1. The adjacent wall of the structure has a fire resistance rating of at least 1 hour.
2. The weatherproof enclosure is constructed of noncombustible materials and it has been demonstrated that a fire within the enclosure will not ignite combustible materials outside the enclosure.

Annex A — Explanatory Material

A4.1.4 (2) Means of demonstrating compliance are by means of full scale fire test or by calculation procedures.

Because of the limited spaces that are frequently available for installation, it has become apparent that exception (2) would be beneficial for many residential and commercial installations. With that in mind, the manufacturer contracted with an independent testing laboratory to run full scale fire tests to assure that the Eaton enclosure would not ignite combustible materials outside the enclosure.

The criteria was to determine the worst case fire scenario within the generator and to determine the ignitability of items outside the engine enclosure at various distances. The Eaton enclosure is constructed of non-combustible materials and the results and conclusions from the independent testing lab indicated that any fire within the generator enclosure would not pose any ignition risk to nearby combustibles or structures, with or without fire service personnel response.

Based on this testing and the requirements of NFPA 37, Sec 4.1.4, the guidelines for installation of the generators listed above are changed to 18 inches (457mm) from the back side of the generator to a stationary wall or building. For adequate maintenance and airflow clearance, the area above the generator should be at least 4 feet with a minimum of 3 feet at the front and ends of the enclosure. This would include trees, shrubs and vegetation that could obstruct airflow. See the diagram on the reverse of this page and the installation drawing within the owner's manual for details.

Generator exhaust contains **DEADLY** carbon monoxide gas. This dangerous gas can cause unconsciousness or death. Do not place the unit near windows, doors, fresh air intakes (furnaces, etc.) or any openings in the building or structure, including windows and doors of an attached garage.

Figure 1.10 – Installation Guidelines

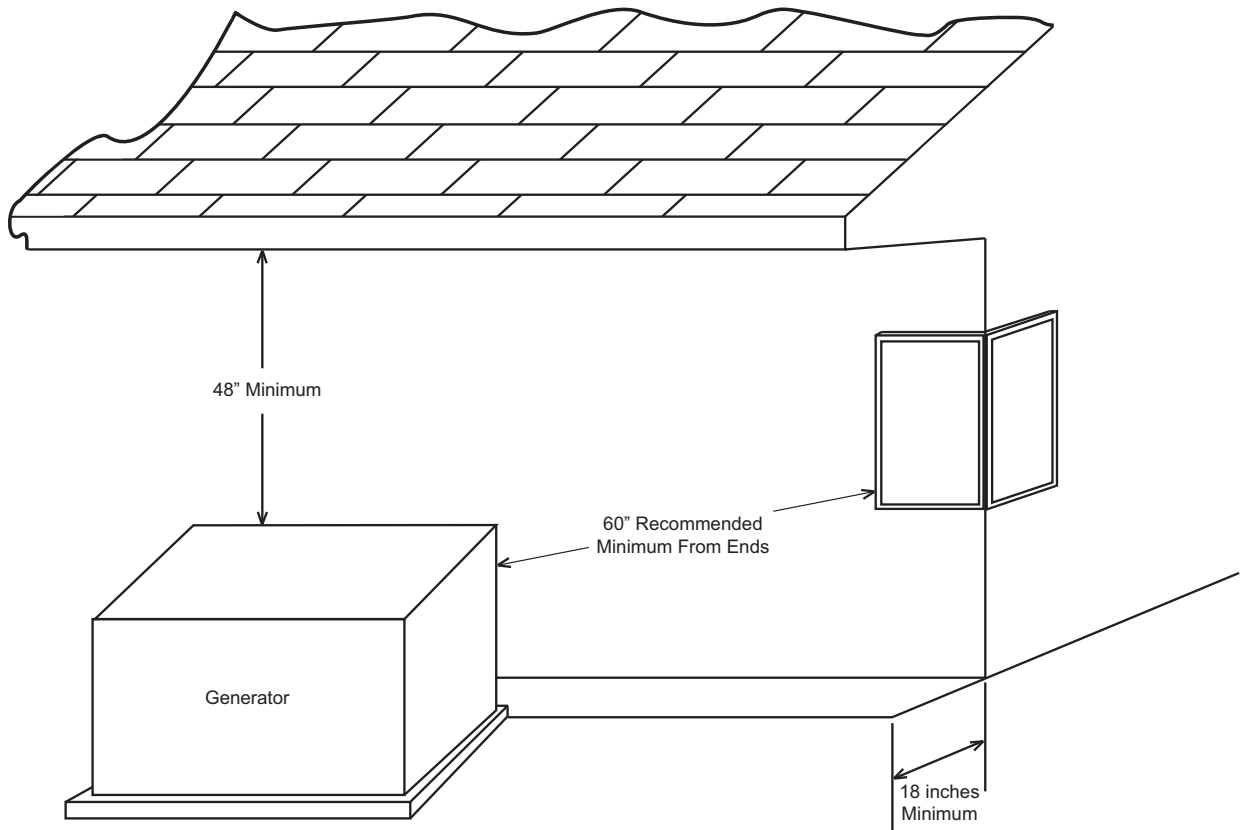
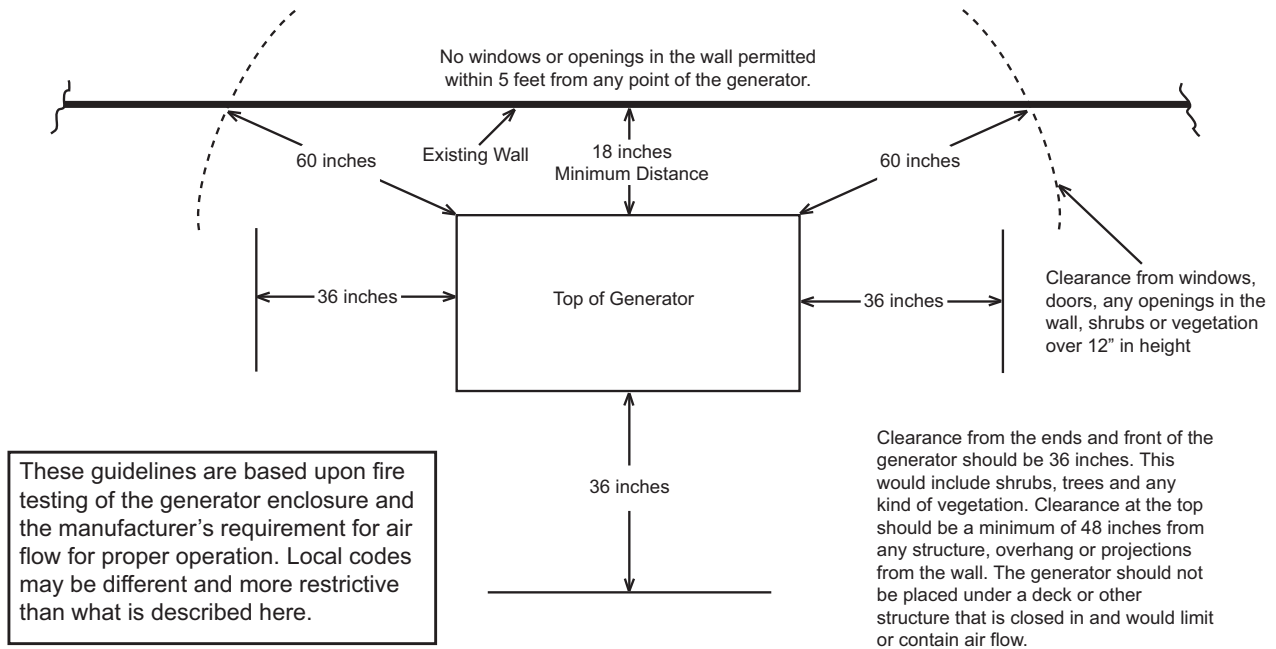

1.12 BATTERY REQUIREMENTS

See the Specifications section for correct battery size and rating

⚠ WARNING ⚠

- ⚠ If the AUTO/OFF/MANUAL switch is not set to its OFF position, the generator can crank and start as soon as the battery cables are connected. If the utility power supply is not turned off, sparking can occur at the battery posts and cause an explosion.

1.13 BATTERY INSTALLATION

Fill the battery with the proper electrolyte fluid if necessary and have the battery fully charged before installing it.

Before installing and connecting the battery, complete the following steps:

1. Set the generator's AUTO/OFF/MANUAL switch to OFF.
2. Turn off utility power supply to the transfer switch.
3. Remove the 7.5A fuse from the generator control panel.

Battery cables were factory connected at the generator (Figure 1.11). Connect cables to battery posts as follows:

4. Connect the red battery cable (from starter contactor) to the battery post indicated by a positive, POS or (+).
5. Connect the black battery cable (from frame ground) to the battery post indicated by a negative, NEG or (—).

Figure 1.11 – Battery Cable Connections

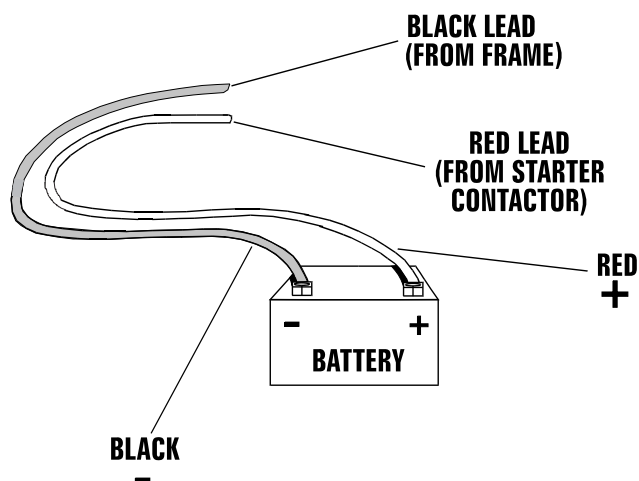

NOTE:

Dielectric grease should be used on battery posts to aid in the prevention of corrosion.

NOTE:

Damage will result if battery connections are made in reverse.

NOTE:

In areas where temperatures regularly fall below 10° F (-12° C) it is recommended that a pad type battery heater be installed to aid in cold climate starting.

1.14 THE BATTERY

⚠ DANGER ⚠

- ⚠ Do not dispose of the battery in a fire. The battery is capable of exploding.
- ⚠ A battery presents a risk of electrical shock and high short circuit current. The following precautions are to be observed when working on batteries:
 - Remove the 7.5A fuse from the generator control panel.
 - Remove watches, rings or other metal objects;
 - Use tools with insulated handles;
 - Wear rubber gloves and boots;
 - Do not lay tools or metal parts on top of the battery; and
 - Disconnect charging source prior to connecting or disconnecting battery terminals.

⚠ WARNING ⚠

- ⚠ Do not open or mutilate the battery. Released electrolyte has been known to be harmful to the skin and eyes, and to be toxic.
- ⚠ The electrolyte is a dilute sulfuric acid that is harmful to the skin and eyes. It is electrically conductive and corrosive.

The following procedures are to be observed:

- Wear full eye protection and protective clothing;
- Where electrolyte contacts the skin, wash it off immediately with water;
- Where electrolyte contacts the eyes, flush thoroughly and immediately with water and seek medical attention; and
- Spilled electrolyte is to be washed down with an acid neutralizing agent. A common practice is to use a solution of 1 pound (500 grams) bicarbonate of soda to 1 gallon (4 liters) of water. The bicarbonate of soda solution is to be added until the evidence of reaction (foaming) has ceased. The resulting liquid is to be flushed with water and the area dried.
- ⚠ Lead-acid batteries present a risk of fire because they generate hydrogen gas. The following procedures are to be followed:
 - DO NOT SMOKE when near the battery;
 - DO NOT cause flame or spark in battery area; and
 - Discharge static electricity from body before touching the battery by first touching a grounded metal surface.

 **Be sure the AUTO/OFF/MANUAL switch is set to the OFF position before connecting the battery cables. If the switch is set to AUTO or MANUAL, the generator can crank and start as soon as the battery cables are connected.**

 **Be sure the utility power supply is turned off and the 7.5A fuse is removed from the generator control panel, or sparking may occur at the battery posts as the cables are attached and cause an explosion.**

Servicing of the battery is to be performed or supervised by personnel knowledgeable of batteries and the required precautions. Keep unauthorized personnel away from batteries.

See the Specifications section for the correct size and rating when replacing the battery. Have these procedures performed at the intervals specified in the "Service Schedule." A negative ground system is used. Battery connections are shown on the wiring diagrams. Make sure the battery is correctly connected and terminals are tight. Observe battery polarity when connecting the battery to the generator set.

1.15 BATTERY CHARGER

NOTE:

These generators **DO NOT** contain an internal battery charger.

NOTE:

The manufacturer provides a battery trickle charger that is active when the unit is set up for automatic operation. With the battery installed and utility power source voltage available to the transfer switch, the battery receives a trickle charge to prevent self-discharge. The trickle charger is designed to help extend the life of the battery by maintaining the battery. The trickle charge feature cannot be used to recharge a discharged battery.

A separate battery charger module is included with the generator.

(For battery charger installation, see the Generator Install Guidelines included with the unit.)

2.1 BEFORE INITIAL START-UP

NOTE:

These units have been run and tested at the factory prior to being shipped and do not require any type of break-in.

Before starting, complete the following:

1. Set the generator's main circuit breaker to its OFF (or OPEN) position.
2. Set the generator's AUTO/OFF/MANUAL switch to the OFF position.
3. Turn OFF all loads connected to the transfer switch terminals T1 and T2.
4. Check the engine crankcase oil level and, if necessary, fill to the dipstick FULL mark with the recommended oil. Do not fill above the FULL mark.

5. Check the fuel supply. Gaseous fuel lines must have been properly purged and leak tested in accordance with applicable fuel-gas codes. All fuel shutoff valves in the fuel supply lines must be open.

During initial start up only, the generator may exceed the normal number of start attempts and experience an "over crank" fault (See the "Overcrank" section). This is due to accumulated air in the fuel system during installation. Reset the control board and restart up to two more times, if necessary. If unit fails to start, contact the local dealer for assistance.

—  **CAUTION**  —

 **Never operate the engine with the oil level below the "Add" mark on the dipstick. Doing this could damage the engine.**

2.2 ELECTRICAL CHECKS

Complete electrical checks as follows:

1. Set the generator's main circuit breaker to its OFF (or OPEN) position.
2. Set the generator's AUTO/OFF/MANUAL switch to the OFF position.
3. Turn OFF all loads connected to the transfer switch terminals T1 and T2.
4. Turn on the utility power supply to the transfer switch using the means provided (such as a utility main line circuit breaker).

—  **DANGER**  —

 **The transfer switch is now electrically "hot." Contact with "hot" parts will result in extremely hazardous and possibly fatal electrical shock. Proceed with caution.**

5. Use an accurate AC voltmeter to check utility power source voltage across transfer switch terminals N1 and N2. Nominal line-to-line voltage should be 240 volts AC.
6. Check utility power source voltage across terminals N1 and the transfer switch neutral lug; then across terminal N2 and neutral. Nominal line-to-neutral voltage should be 120 volts AC.
7. When certain that utility supply voltage is compatible with transfer switch and load circuit ratings, turn OFF the utility power supply to the transfer switch.
8. On the generator panel, set the Auto/Off/ Manual switch to MANUAL. The engine should crank and start.
9. Let the engine warm up for about five minutes to allow internal temperatures to stabilize. Then, set the generator's main circuit breaker to its ON (or closed) position.

—  **DANGER**  —

 **Proceed with caution! Generator power voltage is now supplied to the transfer switch. Contact with live transfer switch parts will result in dangerous and possibly fatal electrical shock.**

10. Connect an accurate AC voltmeter and a frequency meter across transfer switch terminal lugs E1 and E2. 8kW voltage should be 230-240 volts at a frequency of 61-63 Hertz. 14, 17 and 20kW voltage should be 247-249 at a frequency of 59.5-60.5 Hertz. 10kW voltage should be 220-230 volts at a frequency of 59.5-60.5 Hertz.
11. Connect the AC voltmeter test leads across terminal lugs E1 and neutral; then across E2 and neutral. In both cases, voltage reading should be 121-126 volts AC (8kW), and 125-126 volts AC (10, 14, 17 and 20kW).
12. Set the generator's main circuit breaker to its OFF (or OPEN) position. Let the engine run at no-load for a few minutes to stabilize internal engine generator temperatures.
13. Set the generator's AUTO/OFF/MANUAL switch to OFF. The engine should shut down.

NOTE:

It is important not to proceed until certain that generator AC voltage and frequency are correct and within the stated limits. Generally, if both AC frequency and voltage are high or low, the engine governor requires adjustment* (*GH410 only). If frequency is correct, but voltage is high or low, the generator's voltage regulator requires adjustment.

2.3 GENERATOR TESTS UNDER LOAD

To test the generator set with electrical loads applied, proceed as follows:

1. Set generator's main circuit breaker to its OFF (or OPEN) position.
2. Turn OFF all loads connected to the transfer switch terminals T1 and T2.
3. Set the generator's AUTO/OFF/MANUAL switch to OFF.
4. Turn OFF the utility power supply to the transfer switch, using the means provided (such as a utility main line circuit breaker).

⚠ WARNING ⚠

Do not attempt manual transfer switch operation until all power voltage supplies to the transfer switch have been positively turned off. Failure to turn off all power voltage supplies will result in extremely hazardous and possibly fatal electrical shock.

5. Manually set the transfer switch to the STANDBY position, i.e., load terminals connected to the generator's E1/E2 terminals. The transfer switch operating lever should be down.
6. Set the generator's AUTO/OFF/MANUAL switch to MANUAL. The engine should crank and start immediately.
7. Let the engine stabilize and warm up for a few minutes.
8. Set the generator's main circuit breaker to its ON (or CLOSED) position. Loads are now powered by the standby generator.
9. Turn ON the load center fed by the transfer switch (T1 and T2).

10. Connect an accurate AC voltmeter and a frequency meter across terminal lugs E1 and E2.
 - 8kW voltage should be greater than 230 volts and frequency should be greater than 58 Hz.
 - 10, 14, 17 and 20kW voltage should be greater than 240 volts and frequency should be 60 Hz.
11. Let the generator run at full rated load for 20-30 minutes. Listen for unusual noises, vibration or other indications of abnormal operation. Check for oil leaks, evidence of overheating, etc.
12. When testing under load is complete, turn OFF electrical loads.
13. Set the generator's main circuit breaker to its OFF (or OPEN) position.
14. Let the engine run at no-load for a few minutes.
15. Set the AUTO/OFF/MANUAL switch to OFF. The engine should shut down.

2.4 CHECKING AUTOMATIC OPERATION

To check the system for proper automatic operation, proceed as follows:

1. Set generator's main circuit breaker to its OFF (or OPEN) position.
2. Check that the AUTO/OFF/MANUAL switch is set to OFF.
3. Turn OFF the utility power supply to the transfer switch, using means provided (such as a utility main line circuit breaker).
4. Manually set the transfer switch to the UTILITY position, i.e., load terminals connected to the utility power source side.
5. Turn ON the utility power supply to the transfer switch, using the means provided (such as a utility main line circuit breaker).
6. Set the generator's main circuit breaker to its ON (or CLOSED) position.
7. Set the AUTO/OFF/MANUAL switch to AUTO. The system is now ready for automatic operation.
8. Turn OFF the utility power supply to the transfer switch.

With the AUTO/OFF/MANUAL switch at AUTO, the engine should crank and start when the utility source power is turned OFF after a 10 second delay. After starting, the transfer switch should connect load circuits to the standby side after a 20 to 50 second selectable delay. Let the system go through its entire automatic sequence of operation.

With the generator running and loads powered by generator AC output, turn ON the utility power supply to the transfer switch. The following should occur:

- After about 10 seconds, the switch should transfer loads back to the utility power source.
- About one minute after re-transfer, the engine should shut down.
-

2.5 ENGINE GOVERNOR ADJUSTMENT

If both AC frequency and voltage are correspondingly high or low, adjust the engine governor as follows:

◆ 2.5.1 8 KW UNITS



▲ The engine must be OFF to perform steps 1 and 2.

1. Loosen the governor clamp bolt (Figure 2.1).
2. Hold the governor lever at its wide open throttle position (clockwise), and rotate the governor shaft clockwise as far as it will go. Then, tighten the governor lever clamp bolt to 70 inch-pounds (8 N-m).
3. Start the generator; let it stabilize and warm up at no-load.
4. Connect a frequency meter across the generators AC output leads.

Figure 2.1 — Engine Governor Adjustment Single Cylinder Engines

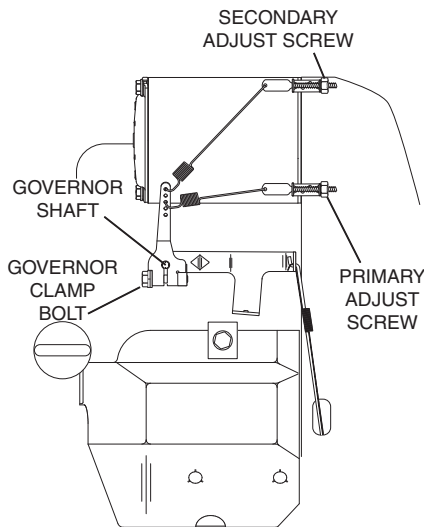

5. Turn the primary adjust screw to obtain a frequency reading of 61.5 Hertz. Turn the secondary adjust screw to obtain a frequency of 62.5 Hz.

◆ 2.5.2 10, 14, 17 & 20KW UNITS

NOTE:

All V-twin units **DO NOT** require an engine governor adjustment due to their design.

◆ 2.5.3 ADDITIONAL CORROSION PROTECTION

Periodically spray all engine linkage parts and brackets with corrosion inhibiting spray such as WD-40 or a comparable product.

2.6 VOLTAGE REGULATOR ADJUSTMENT

◆ 2.6.1 8 & 10KW UNITS

Due to the brushless design of these two alternators, no voltage regulator is used and therefore no voltage adjustment is required.

◆ 2.6.2 14, 17 & 20KW UNITS

With the frequency between 59.5 -60.5 Hertz at no-load, slowly turn the slotted potentiometer (Figure 2.2) until line voltage reads 247-249 volts.

Figure 2.2 – Voltage Adjustment Potentiometer

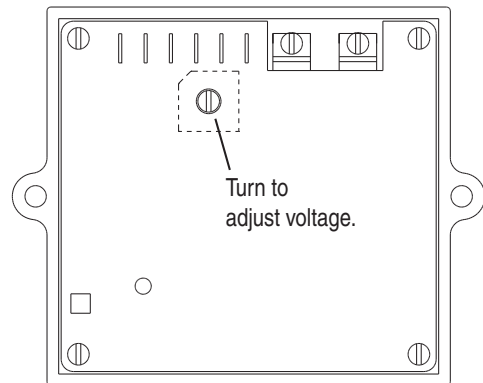

NOTE:

The access panel on top of the control panel must be removed to adjust the voltage regulator.

NOTE:

The voltage regulator is housed behind the generator's control panel. The regulator maintains a voltage in direct proportion to frequency at a 2-to-1 ratio. For example, at 60 Hertz, line-to-neutral voltage will be 124 volts.

3.1 CONTROL PANEL INTERFACE

◆ 3.1.1 USING THE AUTO/OFF/MANUAL SWITCH

(FIGURES 3.1 & 3.2)

1. "AUTO" Position – Selecting this switch activates fully automatic system operation. It also allows the unit to automatically start and exercise the engine every seven days with the setting of the exercise timer (see the Setting the Exercise Timer section).
2. "OFF" Position – This switch position shuts down the engine. This position also prevents automatic operation.
3. "MANUAL" Position – Set the switch to MANUAL to crank and start the engine. Transfer to standby power will not occur unless there is a utility failure.

Figure 3.1 – 8kW Generator Control Panel

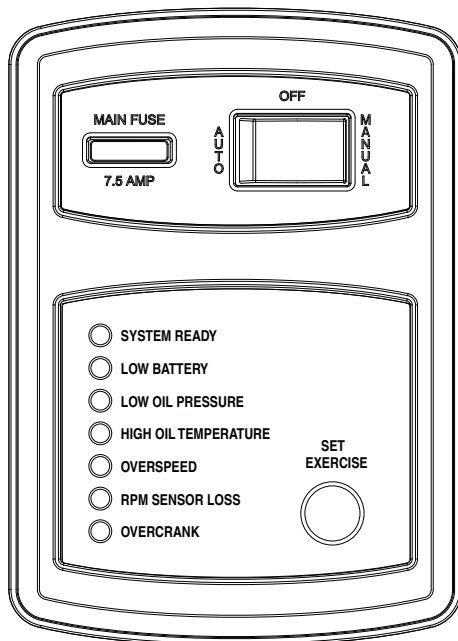

⚠ WARNING ⚠

⚠ With the switch set to AUTO, the engine may crank and start at any time without warning. Such automatic starting occurs when utility power source voltage droops below a preset level or during the normal exercise cycle. To prevent possible injury that might be caused by such sudden starts, always set the switch to OFF and remove the fuses before working on or around the generator or transfer switch. Then, place a "DO NOT OPERATE" tag on the generator panel and on the transfer switch.

Figure 3.2 – 10/14/17 & 20kW Generator Control Panel

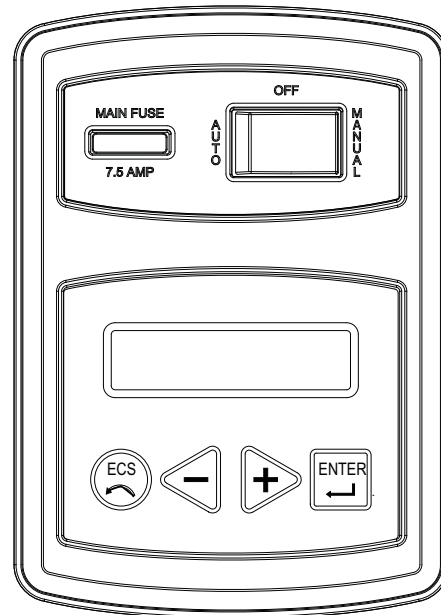

◆ 3.1.2 SETTING THE EXERCISE TIMER

This generator is equipped with an exercise timer. Once it is set, the generator will start and exercise every seven days, on the day of the week and at the time of day specified. During this exercise period, the unit runs for approximately 12 minutes and then shuts down. Transfer of loads to the generator output does not occur during the exercise cycle unless utility power is lost.

✦ 8kW

A switch on the control panel (see Figure 3.1) permits selection of the day and time for the system to exercise. At the chosen time, perform the following sequence to select the desired day and time of day the system will exercise. Remember seasonal time changes affect the exercise settings.

1. Verify that the AUTO/OFF/MANUAL switch is set to AUTO.
2. Press and hold the "Set Exercise" switch for several seconds. All the red LED's will stop flashing immediately and the generator will start.
3. The generator will start and run for approximately 12 minutes and then shut down. The exerciser is now set to run at this time of day each week.

Example: If the "Set Exercise" pressed on Saturday afternoon at 2:00 p.m., the generator will start and exercise for approximately 12 minutes every Saturday at 2:00 p.m.

NOTE:

The exerciser will only work in the AUTO mode and will not work unless this procedure is performed. The exerciser will need to be reset every time the 12 volt battery is disconnected and then reconnected, and when the fuse is removed and/or replaced.

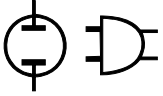

✦ 10 to 20 KW - INSTALLATION ASSISTANT

Upon first power up of the generator, the display interface will begin an installation assistant. The assistant will prompt the user to set the minimum settings to operate. These settings are simply: Current Date/Time and Exercise Day/Time. The maintenance intervals will be initialized when the exercise time is entered (Figure 3.2).

The exercise settings can be changed at any time via the "EDIT" menu (see Appendix, "Menu System").

If the 12 volt battery is disconnected or the fuse removed, the Installation Assistant will operate upon power restoration. The only difference is the display will only prompt the customer for the current Time and Date.

IF THE INSTALLER TESTS THE GENERATOR PRIOR TO INSTALLATION, PRESS THE "ENTER" KEY TO AVOID SETTING UP THE EXERCISE TIME. THIS WILL ENSURE THAT WHEN THE CUSTOMER POWERS UP THE UNIT, HE WILL STILL BE PROMPTED TO ENTER AN EXERCISE TIME.

NOTE:

The exerciser will only work in the AUTO mode and will not work unless this procedure is performed. The current date/time will need to be reset every time the 12 volt battery is disconnected and then reconnected, and/or when the fuse is removed.

◆ 3.1.3 DISPLAY INTERFACE

✦ 8 kW LED Display

Seven (7) LED's are provided for user status indications. The LED functions are:

1. System Ready (green)
2. Low Battery (red)
3. Low Oil Pressure (red)
4. High Oil Temperature (red)
5. Over Speed (red)
6. RPM Sensor Loss (red)
7. Over Crank (red)

See the Protection Systems section for details.

✦ 10 to 20KW DISPLAY INTERFACE MENUS

The LCD display is organized as detailed below:

- The "Home" page, this page is the default page which will be displayed if no keys are pressed for 30 seconds. This page normally shows the current Status message and the current date and time. The highest priority active Alarm and/or Warning will be automatically posted on this page as well as flashing the backlight when such an event is detected. In the case of multiple Alarms or Warnings, only the first message will be displayed. To clear an Alarm or Warning, see the Protection Systems section - Clear Alarm.
- The display backlight is normally off. If the user presses any key, the backlight will come on automatically and remain on for 30 seconds after the last key was pressed.

- The "Main Menu" page will allow the user to navigate to all other pages or sub-menus by using the Left/Right and Enter keys. This page can be accessed at any time with several presses of the dedicated Escape key. Each press of the Escape key takes you back to the previous menu until the main menu is reached. This page displays the following options: HISTORY; STATUS; EDIT; AND DEBUG. (See the Appendix - "Menu System".)

3.2 AUTOMATIC TRANSFER OPERATION

To select automatic operation, do the following:

1. Make sure the transfer switch main contacts are set to their UTILITY position, i.e., loads connected to the utility power source (Figure 3.2).
2. Be sure that normal UTILITY power source voltage is available to transfer switch terminal lugs N1 and N2 (Refer to the Electrical Data section).
3. Set the generator's AUTO/OFF/MANUAL switch to AUTO.
4. Set the generator's main circuit breaker to its ON (or CLOSED) position.

With the preceding steps complete, the generator will start automatically when utility source voltage drops below a preset level. After the unit starts, loads are transferred to the standby power source. Refer to the Sequence of Automatic Operation section.

3.3 SEQUENCE OF AUTOMATIC OPERATION

◆ 3.3.1 UTILITY FAILURE

Initial Conditions: Generator in Auto, ready to run, load being supplied by utility source. When utility fails (below 70% of nominal), a 10 second line interrupt delay time is started. If the utility is still gone when the timer expires, the engine will crank and start. Once started, a 20 to 50 second selectable engine warm-up timer will be initiated. When the warm-up timer expires, the control will transfer the load to the generator. If the utility power is restored (above 80% of nominal) at any time from the initiation of the engine start until the generator is ready to accept load (and the warm-up time has not elapsed), the controller will complete the start cycle and run the generator through its normal cool down cycle; however, the load will remain on the utility source.

◆ 3.3.2 CRANKING

The system will control the cyclic cranking as follows: 16 second crank, seven (7) second rest, 16 second crank, seven (7) second rest followed by three (3) additional cycles of seven (7) second cranks followed by seven (7) second rests.

✦ Choke Operation

1. The 990/999cc engines have an electric choke in the air box that is automatically controlled by the electronic control board.
2. The 530cc engines have an electric choke on the divider panel air inlet hose that is automatically controlled by the electronic control board.
3. The 410cc engines have a choke behind the air box that is automatically controlled by the electronic control board.

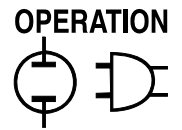

✦ *Failure to Start*

This is defined as any of the following occurrences during cranking.

1. Not reaching starter dropout within the specified crank cycle. Starter dropout is defined as four (4) cycles at 1,000 RPM.
2. Reaching starter dropout, but then not reaching 2200 RPM within 15 seconds. In this case the control board will go into a rest cycle for seven (7) seconds, then continue the rest of the crank cycle.

During a rest cycle the start and fuel outputs are de-energized and the magneto output is shorted to ground.

✦ *Cranking Conditions*

The following notes apply during cranking cycle.

1. Starter motor will not engage within five (5) seconds of the engine shutting down.
2. The fuel output will not be energized with the starter.
3. The starter and magneto outputs will be energized together.
4. Once the starter is energized the control board will begin looking for engine rotation. If it does not see an RPM signal within three (3) seconds it will shut down and latch out on RPM sensor loss.
5. Once the control board sees an RPM signal it will energize the fuel solenoid, drive the throttle open and continue the crank sequence.
6. Starter motor will disengage when speed reaches starter dropout.
7. If the generator does not reach 2200 RPM within 15 seconds, re-crank cycle will occur.
8. If engine stops turning between starter dropout and 2200 RPM, the board will go into a rest cycle for seven (7) seconds then re-crank (if additional crank cycles exist).
9. Once started, the generator will wait for a hold-off period before starting to monitor oil pressure and oil temperature (refer to the Alarm Messages section for hold-off times).
10. During Manual start cranking, if the Mode switch is moved from the Manual position, the cranking stops immediately.
11. During Auto mode cranking, if the Utility returns, the cranking cycle does NOT abort but continues until complete. Once the engine starts, it will run for one (1) minute, then shut down.

◆ **3.3.3 LOAD TRANSFER**

The transfer of load when the generator is running is dependent upon the operating mode as follows:

1. Manual
 - Will not transfer to generator if utility is present.
 - Will transfer to generator if utility fails (below 70% of nominal for 20 or 50 consecutive seconds.
 - Will transfer back when utility returns for 10 consecutive seconds. The engine will continue to run until removed from the Manual mode.

2. Auto
 - Will start and run if Utility fails for 10 consecutive seconds.
 - Will start a 20 to 50 second selectable engine warm-up timer.
 - Will not transfer if utility subsequently returns.
 - Will transfer to generator if utility is still not present.
 - Will transfer back to utility once utility returns (above 80% of nominal) for 10 seconds.
 - Will transfer back to utility (IF available) if the generator is shut down for any reason (such as the switch is in the OFF position) or a shutdown alarm and the utility source is available.
 - After transfer, will shut down engine after one (1) minute cool-down time.
3. Exercise
 - Will not exercise if generator is already running in either Auto or Manual mode.
 - During exercise, the controller will only transfer if utility fails during exercise for 10 seconds, and will switch to Auto mode.

◆ **3.3.4 UTILITY RESTORED**

Initial Condition: Generator supplying power to customer load. When the utility returns (above 80% of nominal), a 10 second return to utility timer will start. At the completion of this timer, if the utility supply is still present and acceptable, the control will transfer the load back to the utility and run the engine through a one (1) minute cool down period and then shut down. If utility fails during this cool down period, the control will transfer load back to the generator and continue to run while monitoring for utility to return.

3.4 MANUAL TRANSFER OPERATION

◆ **3.4.1 TRANSFER TO GENERATOR POWER SOURCE**

To start the generator and activate the transfer switch manually, proceed as follows:

1. Set the generator's AUTO/OFF/MANUAL switch to OFF.
2. Set the generator's main circuit breaker to its OFF (or OPEN) position.
3. Turn OFF the utility power supply to the transfer switch using the means provided (such as a utility main line circuit breaker).



 **Do not attempt to activate the transfer switch manually until all power voltage supplies to the switch have been positively turned off. Failure to turn off all power voltage supplies may result in extremely hazardous and possibly fatal electrical shock.**

4. Use the manual transfer handle inside the transfer switch to move the main contacts to their STANDBY position, i.e., loads connected to the standby power source (Figure 3.3).

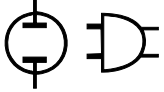

5. To crank and start the engine, set the AUTO/OFF/MANUAL switch to MANUAL.
6. Let the engine stabilize and warm up for a few minutes.
7. Set the generator's main circuit breaker to its ON (or CLOSED) position. The standby power source now powers the loads.

Figure 3.3 – Manual Transfer Switch Operation

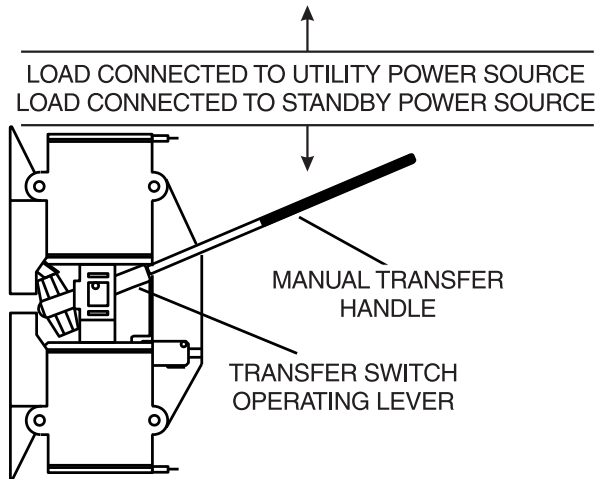

◆ 3.4.2 TRANSFER BACK TO UTILITY POWER SOURCE

When utility power has been restored, transfer back to that source and shut down the generator. This can be accomplished as follows:

1. Set the generator's main circuit breaker to its OFF (or OPEN) position.
2. Let the engine run for a minute or two at no-load to stabilize the internal temperatures.
3. Set the generator's AUTO/OFF/MANUAL switch to its OFF (or OPEN) position. The engine should shut down.
4. Check that utility power supply to the transfer switch is turned OFF.

— **⚠ DANGER ⚠** —

⚠ Do not attempt to activate the transfer switch manually until all power voltage supplies to the switch have been positively turned off. Failure to turn off all power voltage supplies may result in extremely hazardous and possibly fatal electrical shock.

5. Use the manual transfer handle inside the transfer switch to move the main contacts back to their UTILITY position, i.e., loads connected to the utility power source (Figure 3.2).
6. Turn ON the utility power supply to the transfer switch using the means provided.
7. Set the system to automatic operation as outlined in Automatic Transfer Operation section.

3.5 SIDE COMPARTMENT (V-TWIN ONLY)

(FIGURES 3.4 & 3.5)

Local codes may require this compartment to be locked. A hasp is provided so the owner can secure the compartment with their own padlock. Check local codes in the area.

◆ 3.5.1 MAIN CIRCUIT BREAKER

This is a 2-pole breaker rated according to the Specifications section.

◆ 3.5.2 EXTERIOR READY LIGHTS

- Green LED 'Ready' light (10, 14, 17 & 20 KW) is on when utility is present and switch is in AUTO indicating the generator is ready and when the generator is running.
- Red LED 'Alarm' light (10, 14, 17 & 20 KW) is on when the generator is OFF or a fault is detected. (See the Protections Systems section.)
- Yellow LED 'Maintenance' light (17 & 20 KW) (See the Protections Systems section.)

◆ 3.5.3 120 VAC GFCI OUTLET & 15 AMP BREAKER (17 & 20 KW ONLY)

These models are equipped with an external, 15 amp, 120 volt, GFCI convenience outlet that is located in a compartment on the right side of generator (Figure 1.3).

When the generator is running, in the absence of utility power, this outlet may also be used to power items outside your home such as lights or power tools. This outlet may also be used when utility power is present by running the generator in manual mode. This outlet does not provide power if the generator is not running. This outlet is protected by a 15 amp circuit breaker in the same compartment as the outlet. (Do not use when the generator is running in exercise mode.)

Figure 3.4 – Side Compartment



Figure 3.5 – Open Side Compartment

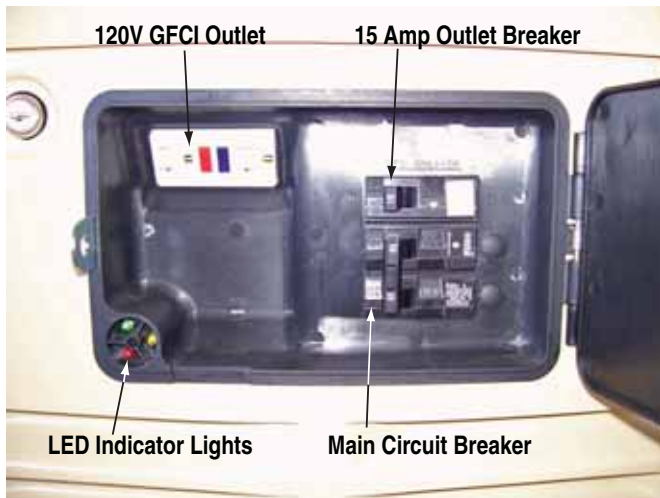
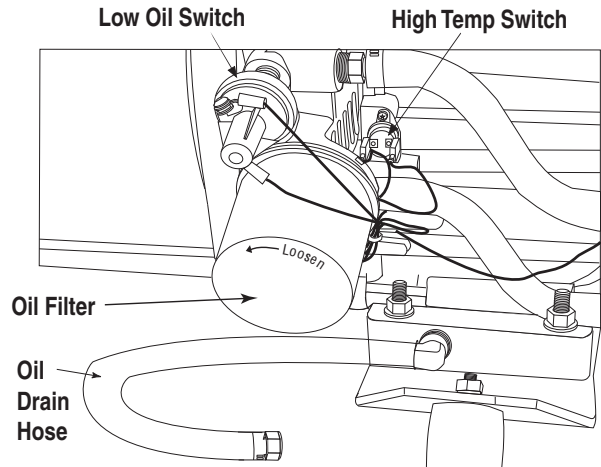

Figure 3.6 – Low Oil Pressure and High Temperature Switches



3.6 PROTECTION SYSTEMS

◆ 3.6.1 ALARMS

Highest Priority (Latching) Displayed on the control panel and the external red LED (V-twins only). They must be cleared before the alarm message goes away. The alarm log records each occurrence (see Appendix - "Menu System").

✦ *Low Oil Pressure (Shutdown Alarm)*

A five (5) second delay on start-up and seven (7) second delay once the engine is running.

This switch (Figure 3.6) has normally closed contacts that are held open by engine oil pressure during operation. Should the oil pressure drop below the five (5) PSI range, switch contacts close and the engine shuts down. The unit should not be restarted until oil level is verified.

✦ *High Engine Temperature (Shutdown Alarm – Auto Reset)*

A 10 second delay on start-up and one (1) second delay before shutdown. Auto reset when the condition clears and restart the engine if a valid start signal is still present.

This switch's contacts (Figure 3.6) close if the temperature should exceed approximately 144° C (293° F), initiating an engine shutdown. Once the oil temperature drops to a safe level the switch's contacts open again.

✦ *Over Crank (Shutdown Alarm)*

This occurs if the engine has not started within the specified crank cycle. (See "Cranking" section.)

NOTE:

The oil drain hose may be routed in the opposite direction as shown in figure.

✦ *Over Speed (Shutdown Alarm)*

4320 RPM for three (3) seconds or 4500 RPM immediately. This feature protects the generator from damage by shutting it down if it happens to run faster than the preset limit. This protection also prevents the generator from supplying an output that could potentially damage appliances connected to the generator circuit. Contact the nearest Dealer if this failure occurs.

✦ *RPM Sense Loss (Shutdown Alarm)*

During cranking, if the Control Board does not see a valid RPM signal within three (3) seconds, it will shut down and lock out on RPM sense loss. While engine is running, if RPM signal is lost for one (1) second the Control Board will shut the engine down, wait 15 seconds, then re-crank the engine. If no RPM signal is detected within the first three (3) seconds of cranking, the Control Board will shut the engine down and latch out on RPM sensor loss. If the RPM signal is detected, the engine will start and run normally. If the RPM signal is subsequently lost again, the Control Board will try one more re-crank attempt before latching out and displaying the RPM sensor failure message.

✦ *Under-frequency (Shutdown Alarm)*

After starting, if the generator stays under frequency for more than 30 seconds it will shut down. The under-frequency setting is 50 Hz.

✦ *Internal Fault (Shutdown Alarm)*

This alarm cannot be cleared, call service dealer.

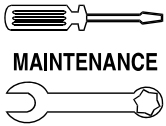

MAINTENANCE

Section 4 — Maintenance

Air-cooled Generators

✦ **CLEAR ALARM**

- 8kW — Clear the alarm by setting the AUTO/OFF/MANUAL switch to the OFF position and back to AUTO.
- 10 - 20kW — Clear the alarm by setting the AUTO/OFF/MANUAL switch to the OFF position. Press the ENTER key to unlatch any active fault and clear the corresponding alarm message.

◆ **3.6.2 WARNINGS**

Second Priority (Non-latching) Displayed on the control panel and the external yellow LED (V-twins only). Warnings automatically clear when the monitored condition goes away. Warnings are recorded in the alarm log. Warnings cannot cause shutdowns.

✦ **Low Battery**

The Control Board monitors battery voltage and displays a warning if the battery voltage falls below 11.0 volts for one (1) minute. Warning is automatically cleared if the battery voltage rises above 11.0 volts. Battery voltage is not monitored during the crank cycle.

✦ **Exercise Set Error**

If the exercise period becomes corrupted, a warning message will be displayed. This message will only clear when the exercise period is reset.

◆ **3.6.3 MAINTENANCE ALERTS (10 - 20KW ONLY)**

Third priority

✦ **Maintenance Message**

When a maintenance period expires, a warning message will be displayed. (17 through 20kW models include an external yellow LED which will illuminate.) The alert can be reset by pressing the Enter key, which will cause the user to be prompted to confirm the action. Resetting will clear the alert and reset the maintenance counters for all conditions annunciated. The history log will record the alert. The maintenance counter will not accumulate without battery power. Once battery power is restored, the set time prompt will be displayed. The maintenance counters will be adjusted to the new time and date.

NOTE:

Since most maintenance alerts will occur at the same time (most have two (2) year intervals), only one will appear on the display at any one time. Once the first alert is cleared, the next active alert will be displayed.

4.1 FUSE

The 7.5 amp fuse on the control panel protects the DC control circuit against overload (Figures 3.1 and 3.2). This fuse is wired in series with the battery output lead to the panel. If this fuse element has melted open, the engine will not be able to crank or start. Replace this fuse using only an identical 7.5 amp replacement fuse. Whenever the fuse is removed or replaced, the exercise timer needs to be reset.

4.2 CHECKING THE ENGINE OIL LEVEL

For oil capacities, see the Specifications section. For engine oil recommendations, see the Engine Oil Recommendations section.

When power outages necessitate running the generator for extended periods of time, the oil level should be checked daily.

To check the engine oil level, proceed as follows (Figures 4.1, 4.2 and 4.3):

1. If the generator is running during a utility outage, first turn OFF all associated loads running in the residence. Second, turn the generator's main circuit breaker to the OFF position.
2. Move the AUTO/OFF/MANUAL switch to the OFF position.
3. Remove the dipstick and wipe it dry with a clean cloth.
4. Completely insert the dipstick; then, remove it again. The oil level should be at the dipstick "Full" mark. If necessary, add oil to the "Full" mark only. DO NOT FILL ABOVE THE "FULL" MARK.



⚠ **Never operate the engine with the oil level below the "Add" mark on the dipstick. Doing this could damage the engine.**

Figure 4.1 — Oil Dipstick and Fill, 8kW

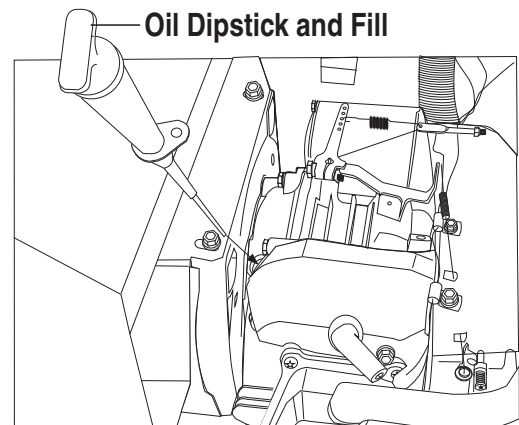
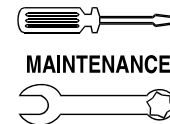

Figure 4.2 — Oil Dipstick, 10kW





5. Install the dipstick.
6. Reset the AUTO/OFF/MANUAL switch to its original position.
7. If the generator was running during a utility outage, first turn the generator's main circuit breaker back to the ON position. Second, turn ON needed loads in the residence.

Figure 4.3 — Oil Dipstick and Fill, 14, 17 & 20kW

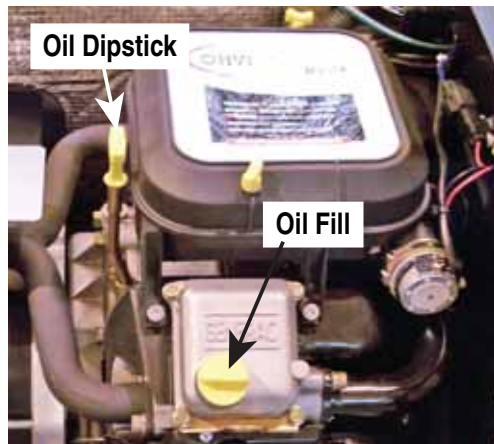

4.3 CHANGING THE ENGINE OIL



Hot oil may cause burns. Allow engine to cool before draining oil. Avoid prolonged or repeated skin exposure with used oil. Thoroughly wash exposed areas with soap.

4.3.1 OIL CHANGE INTERVALS

See the "Service Schedule" section.

4.3.2 ENGINE OIL RECOMMENDATIONS

All oil should meet minimum American Petroleum Institute (API) Service Class SJ, SL or better. Use no special additives. Select the oil's viscosity grade according to the expected operating temperature.

- SAE 30 → Above 32° F
- 10W-30 → Between 40° F and -10° F
- Synthetic 5W-30 → 10° F and below

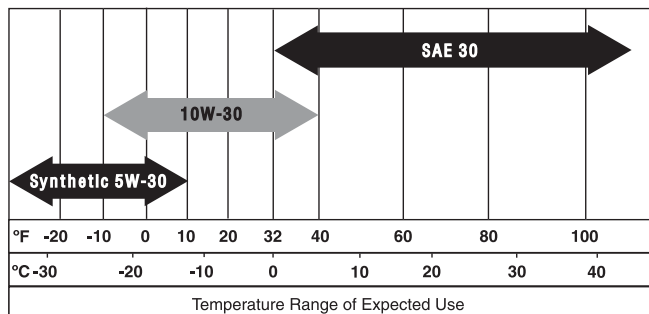

Any attempt to crank or start the engine before it has been properly serviced with the recommended oil may result in an engine failure.

4.3.3 OIL & OIL FILTER CHANGE PROCEDURE

To change the oil, proceed as follows:

1. Start the engine by moving the AUTO/OFF/MANUAL switch to MANUAL and run until it is thoroughly warmed up. Then shut OFF the engine by moving the switch to the OFF position.
2. Immediately after the engine shuts OFF, pull the oil drain hose (Figure 4.4) free of its retaining clip. Remove the cap from the hose and drain the oil into a suitable container.
3. After the oil has drained, replace the cap onto the end of the oil drain hose. Retain the hose in the clip.

Change the engine oil filter as follows:

1. With the oil drained, remove the old oil filter by turning it counterclockwise.
2. Apply a light coating of clean engine oil to the gasket of the new filter. See the Specifications section for recommended filter.
3. Screw the new filter on by hand until its gasket lightly contacts the oil filter adapter. Then, tighten the filter an additional 3/4 to one turn (Figure 4.4).
4. Refill with the proper recommended oil (see the Engine Oil Recommendations section). See the Specifications section for oil capacities.

Figure 4.4 – Oil Drain Hose and Filter

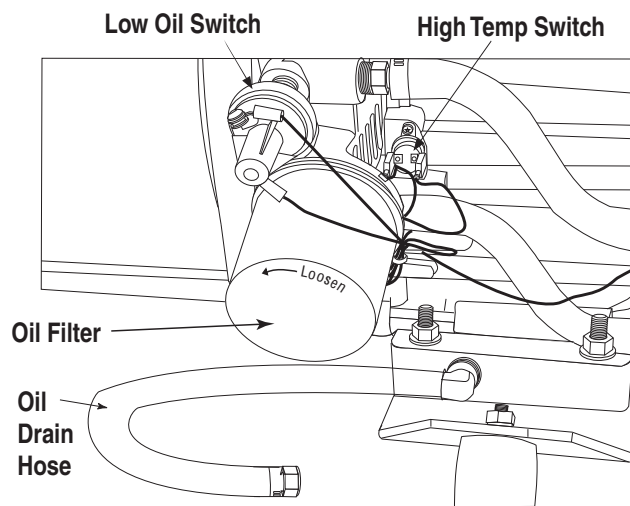

5. Start the engine, run for one (1) minute, and check for leaks.
6. Shutdown and recheck oil level, add as needed. **DO NOT OVER FILL.**
7. Reset the AUTO/OFF/MANUAL switch to the AUTO position.
8. Dispose of used oil at a proper collection center.

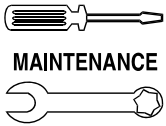

NOTE:

The oil drain hose may be routed in the opposite direction as shown in figure.

4.4 CHANGING THE ENGINE AIR CLEANER

◆ 4.4.1 14, 17 & 20KW GENERATORS

See "The Generator" section for the location of the air cleaner. Use the following procedures (Figure 4.5):

1. Lift the roof and remove the door.
2. Turn the two screws counterclockwise to loosen.
3. Remove the cover and air filter.

Figure 4.5 — 14, 17 & 20kW Engine Air Cleaner

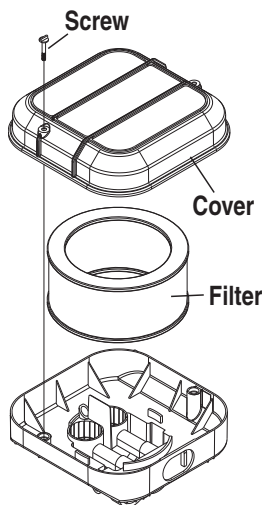

4. Wipe away dust or debris from inside of the air box and around edges.
5. Install the new air cleaner into the air box.
6. Install the cover. Turn the two cover screws clockwise to tighten.

See the Service Schedule section for air cleaner maintenance. See the Specifications section for air filter replacement part number.

◆ 4.4.2 10KW GENERATORS

See "The Generator" section for the location of the air cleaner. Use the following procedure (Figure 4.6):

1. Lift the roof and remove the door.
2. Turn the worm gear clamp screw counterclockwise to loosen.
3. Pull the old filter off the divider panel hub.
4. Wipe away dust or debris from the panel hub.
5. Install the new air cleaner onto the hub.

6. Turn the worm gear clamp screw clockwise to tighten.
7. Replace door and roof.

Figure 4.6 — 10kW Engine Air Cleaner



◆ 4.4.3 8KW GENERATOR

See "The Generator" section to locate the air box. Use the following procedures to replace the dirty air filter within the air box (Figure 4.7).

1. Lift the roof and remove the door.
2. Push back on the latch of the yellow air filter access door to swing open.
3. Pull out the old air filter and discard appropriately.
4. Install the new filter, open end first into the air box.
5. Swing the yellow door shut and snap to close.
6. Replace door and close roof securely.

Figure 4.7 — 8kW Engine Air Cleaner Location

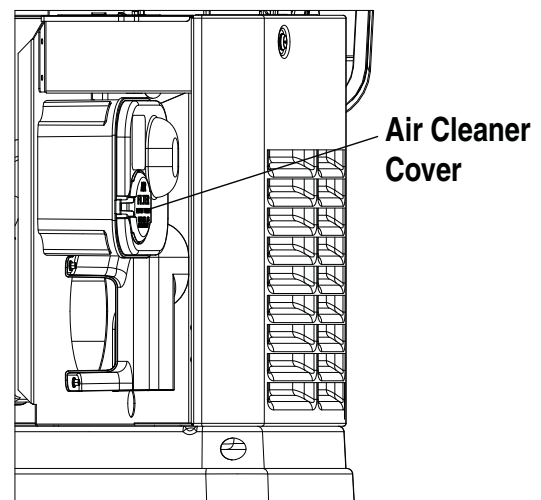

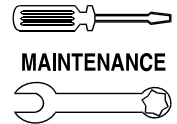

4.5 SPARK PLUG(S)

Reset the spark plug(s) gap or replace the spark plug(s) as necessary. See the Service Schedule section for maintenance requirements.

1. Clean the area around the base of the spark plug(s) to keep dirt and debris out of the engine.
2. Remove the spark plug(s) and check the condition. Replace the spark plug(s) if worn or if reuse is questionable. See the Service Schedule section for recommended inspection. Clean by scraping or washing using a wire brush and commercial solvent. Do not blast the spark plug(s) to clean.
3. Check the spark plug gap using a wire feeler gauge. Adjust the gap to 0.76 mm (0.030 inch) for 8, 10 and 20kW; and 1.02 mm (0.040 inch) for 14 and 17kW by carefully bending the ground electrode (Figure 4.8).

Figure 4.8 – Setting the Spark Plug Gap

SET PLUG GAP AT 0.76 mm (.030 inch) - 8, 10 & 20kW; 1.02 mm (.040 inch) - 14 & 17kW

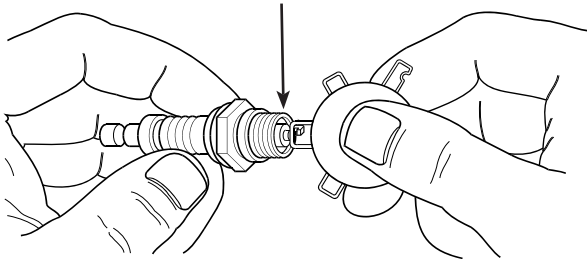

4.6 BATTERY MAINTENANCE

The battery should be inspected per the "Service Schedule" section. The following procedure should be followed for inspection:

1. Inspect the battery posts and cables for tightness and corrosion. Tighten and clean as necessary.
2. Check the battery fluid level of unsealed batteries and, if necessary, fill with Distilled Water Only. Do not use tap water in batteries.
3. Have the state of charge and condition checked. This should be done with an automotive-type battery hydrometer.

⚠ DANGER ⚠

- ⚠ Do not dispose of the battery in a fire. The battery is capable of exploding.
- ⚠ A battery presents a risk of electrical shock and high short circuit current. The following precautions are to be observed when working on batteries:
 - Remove the 7.5A fuse from the generator control panel.
 - Remove watches, rings or other metal objects;
 - Use tools with insulated handles;
 - Wear rubber gloves and boots;
 - Do not lay tools or metal parts on top of the battery; and

- Disconnect charging source prior to connecting or disconnecting battery terminals.

⚠ WARNING ⚠

- ⚠ Do not open or mutilate the battery. Released electrolyte has been known to be harmful to the skin and eyes, and to be toxic.
- ⚠ The electrolyte is a dilute sulfuric acid that is harmful to the skin and eyes. It is electrically conductive and corrosive. The following procedures are to be observed:
 - Wear full eye protection and protective clothing;
 - Where electrolyte contacts the skin, wash it off immediately with water;
 - Where electrolyte contacts the eyes, flush thoroughly and immediately with water and seek medical attention; and
 - Spilled electrolyte is to be washed down with an acid neutralizing agent. A common practice is to use a solution of 1 pound (500 grams) bicarbonate of soda to 1 gallon (4 liters) of water. The bicarbonate of soda solution is to be added until the evidence of reaction (foaming) has ceased. The resulting liquid is to be flushed with water and the area dried.
- ⚠ Lead-acid batteries present a risk of fire because they generate hydrogen gas. The following procedures are to be followed:
 - DO NOT SMOKE when near the battery;
 - DO NOT cause flame or spark in battery area; and
 - Discharge static electricity from body before touching the battery by first touching a grounded metal surface.
- ⚠ Be sure the AUTO/OFF/MANUAL switch is set to the OFF position before connecting the battery cables. If the switch is set to AUTO or MANUAL, the generator can crank and start as soon as the battery cables are connected.
- ⚠ Be sure the utility power supply is turned off and the 7.5A fuse is removed from the generator control panel, or sparking may occur at the battery posts as the cables are attached and cause an explosion.

4.7 ADJUSTING GH-410/GT-530/990/999 VALVE CLEARANCE

After the first six (6) months of operation, check the valve clearance in the engine, adjust if necessary.

Important: If feeling uncomfortable about doing this procedure or the proper tools are not available, please contact the Dealer for service assistance. This is a very important step to ensure longest life for the engine.

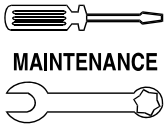

Section 4 — Maintenance

Air-cooled Generators

To check valve clearance:

- The engine should be cool before checking. If valve clearance is 0.002" - 0.004" (0.05 - 0.1mm), adjustment is not needed.
- Remove spark plug wires and position wires away from plugs.
- Remove spark plugs.
- Make sure the piston is at Top Dead Center (TDC) of its compression stroke (both valves closed). To get the piston at TDC, remove the intake screen at the front of the engine to gain access to the flywheel nut. Use a large socket and socket wrench to rotate the nut and hence the engine in a clockwise direction. While watching the piston through the spark plug hole. The piston should move up and down. The piston is at TDC when it is at its highest point of travel.

To adjust valve clearance (if necessary), (Figure 4.9):

- Make sure the engine is at 60° to 80° F.
- Make sure that the spark plug wire is removed from the spark plug and out of the way.
- Remove the four screws attaching the valve cover.
- Loosen the rocker jam nut. Use an 10mm allen wrench to turn the pivot ball stud while checking clearance between the rocker arm and the valve stem with a feeler gauge. Correct clearance is 0.002-0.004 inch (0.05-0.1 mm).

NOTE:

Hold the rocker arm jam nut in place as the pivot ball stud is turned.

When valve clearance is correct, hold the pivot ball stud in place with the allen wrench and tighten the rocker arm jam nut. Tighten the jam nut to 174 in/lbs. torque. After tightening the jam nut, recheck valve clearance to make sure it did not change.

- Install new valve cover gasket.
- Re-attach the valve cover.

Figure 4.9 - Valve Clearance Adjustment

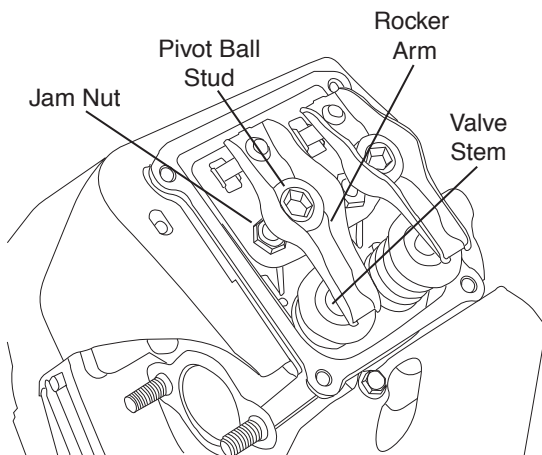

NOTE:

Start all four screws before tightening or it will not be possible to get all the screws in place. Make sure the valve cover gasket is in place.

- Install spark plugs.
- Re-attach the spark plug wire to the spark plug.
- On the GT-530 and GT-990/999, repeat the process for the other cylinder.

4.8 COOLING SYSTEM

Air inlet and outlet openings in the generator compartment must be open and unobstructed for continued proper operation. This includes such obstructions as high grass, weeds, brush, leaves and snow.

Without sufficient cooling and ventilating air flow, the engine/generator quickly overheats, which causes it to quickly shut down. (See Figure 4.10 for vent locations.)

Make sure the doors and roof are in place during operation as running the generator with them removed can effect cooling air movement.

WARNING

- ⚠ The exhaust from this product gets extremely hot and remains hot after shutdown. High grass, weeds, brush, leaves, etc. must remain clear of the exhaust. Such materials may ignite and burn from the heat of the exhaust system.

Figure 4.10 – Cooling Vent Locations

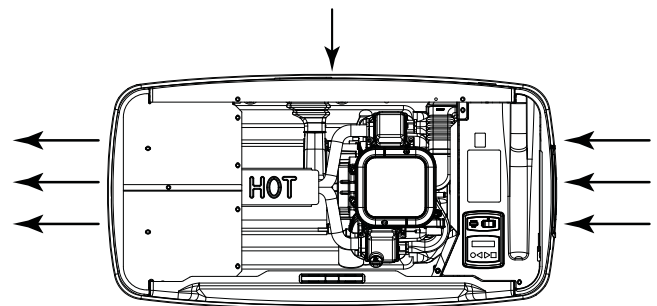

CAUTION

- ⚠ The maximum ambient temperature for the generator is 25° C (77° F).

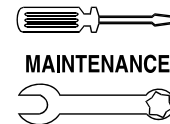

4.9 ATTENTION AFTER SUBMERSION

If the generator has been submerged in water, it **MUST NOT** be started and operated. Following any submersion in water, have a Dealer thoroughly clean, dry and inspect the generator. If the structure (ex. home) has been flooded, it should be inspected by a certified electrician to ensure there won't be any electrical problems during generator operation or when utility is returned.

4.10 CORROSION PROTECTION

Periodically wash and wax the enclosure using automotive type products. Frequent washing is recommended in salt water/coastal areas. Spray engine linkages with a light oil such as WD-40.

4.11 OUT OF SERVICE PROCEDURE

◆ 4.11.1 REMOVAL FROM SERVICE

If the generator cannot be exercised every seven days, and will be out of service longer than 90 days, prepare the generator for storage as follows:

1. Start the engine and let it warm up.
2. Close the fuel shutoff valve in the fuel supply line and allow the unit to shut down.
3. Once the unit has shut down, switch to the OFF position.
4. Set the generator's main circuit breaker to its OFF (or OPEN) position.
5. Set the AUTO/OFF/MANUAL switch to OFF and turn off the utility power to the transfer switch. Remove the 7.5A fuse from the generator control panel. Disconnect the battery cables as outlined in "General Hazards".
6. While the engine is still warm from running, drain the oil completely. Refill the crankcase with oil. See "Engine Oil Recommendations".
7. Attach a tag to the engine indicating the viscosity and classification of the oil in the crankcase.
8. Remove the spark plug(s) and spray fogging agent into the spark plug(s) threaded openings. Reinstall and tighten the spark plug(s).
9. Remove the battery and store it in a cool, dry room on a wooden board. Never store the battery on any concrete or earthen floor.
10. Clean and wipe the entire generator.

◆ 4.11.2 RETURN TO SERVICE

To return the unit to service after storage, proceed as follows:

1. Verify that utility power is turned off and that the AUTO/OFF/MANUAL switch is set to OFF.
2. Check the tag on the engine for oil viscosity and classification. Verify that the correct recommended oil is used in the engine (see the Engine Oil Recommendations section). If necessary, drain and refill with the proper oil.
3. Check the state of the battery. Fill all cells of unsealed batteries to the proper level with distilled water. **DO NOT USE TAP WATER IN THE BATTERY.** Recharge the battery to 100 percent state of charge, or, if defective, replace the battery. See "Specifications," for type and size.
4. Clean and wipe the entire generator.
5. Make sure the 7.5A fuse is removed from the generator control panel. Reconnect the battery. Observe battery polarity. Damage may occur if the battery is connected incorrectly.
6. Open the fuel shutoff valve.
7. Insert the 7.5A fuse into the generator control panel. Start the unit by moving the AUTO/OFF/MANUAL switch to MANUAL. Allow the unit to warm up thoroughly.
8. Stop the unit by setting the AUTO/OFF/MANUAL switch to OFF.
9. Turn on the utility power to the transfer switch.
10. Set the AUTO/OFF/MANUAL switch to AUTO.
11. The generator is now ready for service.

NOTE:

If the battery was dead or disconnected, the exercise timer (single cylinder), current date and time (v-twin) must be reset.

◆ 4.11.3 ACCESSORIES

There are performance enhancing accessories available for the air-cooled generators.

- **Cold Weather Kits** are recommended in areas where temperatures regularly fall below 10° F (-12° C).
- **Scheduled Maintenance Kits** include all pieces necessary to perform maintenance on the generator along with oil recommendations.
- **A Fascia Skirt Wrap** is standard on all 20kW units. It's available for all other current production air-cooled units. It snaps together to provide a smoothing, contoured look as well as rodent/insect protection.
- **The Remote Monitor System** is a wireless, indoor mounted, box that indicates generator run status and allows for exercise programming as well as provide maintenance reminders.
- **Touch-up Paint Kits** are very important to maintain the look and integrity of the generator enclosure. These kits include touch-up paint and instructions if the need should arise.
- For more details on accessories, please contact a Dealer.

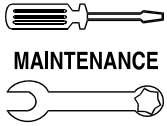

Section 4 — Maintenance

Air-cooled Generators

4.12 SERVICE SCHEDULE

ATTENTION: It is recommended that all service work be performed by the nearest Dealer.

SYSTEM/COMPONENT	PROCEDURE			FREQUENCY
X = Action R = Replace as Necessary * = Notify Dealer if Repair is Needed.	Inspect	Change	Clean	W = Weekly M = Monthly Y = Yearly
FUEL				
Fuel lines and connections*	X			M
LUBRICATION				
Oil level	X			M or 24 hours of continuous operation.
Oil		X		2Y or 200 hours of operation.**
Oil filter		X		2Y or 200 hours of operation.**
COOLING				
Enclosure louvers	X		X	W
BATTERY				
Remove corrosion, ensure dryness	X		X	M
Clean and tighten battery terminals	X		X	M
Check charge state	X	R		EVERY 6 M
Electrolyte level	X	R		EVERY 6 M
ENGINE AND MOUNTING				
Air cleaner	X	R		2Y or 200 hours
Spark plug(s)	X	R		2Y or 200 hours
GENERAL CONDITION				
Vibration, Noise, Leakage, Temperature*	X			M
COMPLETE TUNE-UP*	TO BE COMPLETED BY A DEALER			2Y or 200 hours
* Contact the nearest dealer for assistance if necessary.				
** Change oil and filter after first eight (8) hours of operation and then every 200 hours thereafter, or 2 years, whichever occurs first. Change sooner when operating under a heavy load or in a dusty or dirty environment or in high ambient temperatures.				



5.1 TROUBLESHOOTING GUIDE

Problem	Cause	Correction
The engine will not crank.	<ol style="list-style-type: none"> 1. Fuse blown. 2. Loose, corroded or defective battery cables. 3. Defective starter contactor. (8 kW) 4. Defective starter motor. 5. Dead Battery. 	<ol style="list-style-type: none"> 1. Correct short circuit condition, replace 7.5A fuse in generator control panel. 2. Tighten, clean or replace as necessary. 3. * 4. * 5. Charge or replace battery.
The engine cranks but will not start.	<ol style="list-style-type: none"> 1. Out of fuel. 2. Defective fuel solenoid (FS). 3. Open # 14 wire from engine control board. 4. Fouled spark plug(s). 5. Valve lash out of adjustment. 6. Choke not operating. 	<ol style="list-style-type: none"> 1. Replenish fuel/Turn on fuel valve. 2. * 3. * 4. Clean, re-gap or replace plug(s). 5. Reset valve lash. 6. Verify choke plate moves freely.
The engine starts hard and runs rough.	<ol style="list-style-type: none"> 1. Air cleaner plugged or damaged. 2. Fouled spark plug(s). 3. Fuel pressure incorrect. 4. Fuel selector in wrong position. 5. Choke remains closed. 	<ol style="list-style-type: none"> 1. Check, replace air cleaner. 2. Clean, re-gap or replace plug(s). 3. Confirm fuel pressure to regulator is 10-12" water column (0.36-0.43 psi) for LP, and 5-7" water column (0.18-0.25 psi) for natural gas. 4. Move selector to correct position. 5. Verify choke plate moves freely.
The AUTO/OFF/MANUAL switch is set to OFF, but the engine continues to run.	<ol style="list-style-type: none"> 1. Defective switch. 2. AUTO/OFF/MANUAL switch wired incorrectly. 3. Defective control board. 	<ol style="list-style-type: none"> 1. * 2. * 3. *
There is no AC output from the generator.	<ol style="list-style-type: none"> 1. Main line circuit breaker is in the OFF (or OPEN) position. 2. Generator internal failure. 	<ol style="list-style-type: none"> 1. Reset circuit breaker to ON (or CLOSED). 2. *
There is no transfer to standby after utility	<ol style="list-style-type: none"> 1. Defective transfer switch coil. 2. Defective control logic board. 	<ol style="list-style-type: none"> 1. * 2. *
Unit consumes large amounts of oil.	<ol style="list-style-type: none"> 1. Engine over filled with oil. 2. Improper type or viscosity of oil. 3. Damaged gasket, seal or hose. 4. Engine breather defective. 	<ol style="list-style-type: none"> 1. Adjust oil to proper level. 2. See "Engine Oil Recommendations". 3. Check for oil leaks. 4. *

*Contact the nearest Dealer for assistance.



6.1 MENU SYSTEM NAVIGATION

To get to the MENU, use the "Esc" key from any page. It may need to be pressed many times before getting to the menu page. The currently selected menu is displayed as a flashing word. Navigate to the menu required by using the +/- keys. When the menu required is flashing, press the ENTER key. Depending on the menu selected, there may be a list of choices presented. Use the same navigation method to select the the desired screen (refer to the Menu System diagram).

◆ 6.1.1 CHANGING SETTINGS (EDIT MENU)

To change a setting such as display contrast, go to the EDIT menu and use the +/- keys to navigate to the setting to change. Once this setting is displayed (e.g. Contrast), press the ENTER key to go into the edit mode. Use the +/- keys to change the setting, press the ENTER key to store the new setting.

NOTE:

If the ENTER key is not pressed to save the new setting, it will only be saved temporarily. The next time the battery is disconnected, the setting will revert back to the old setting.

MENU SYSTEM

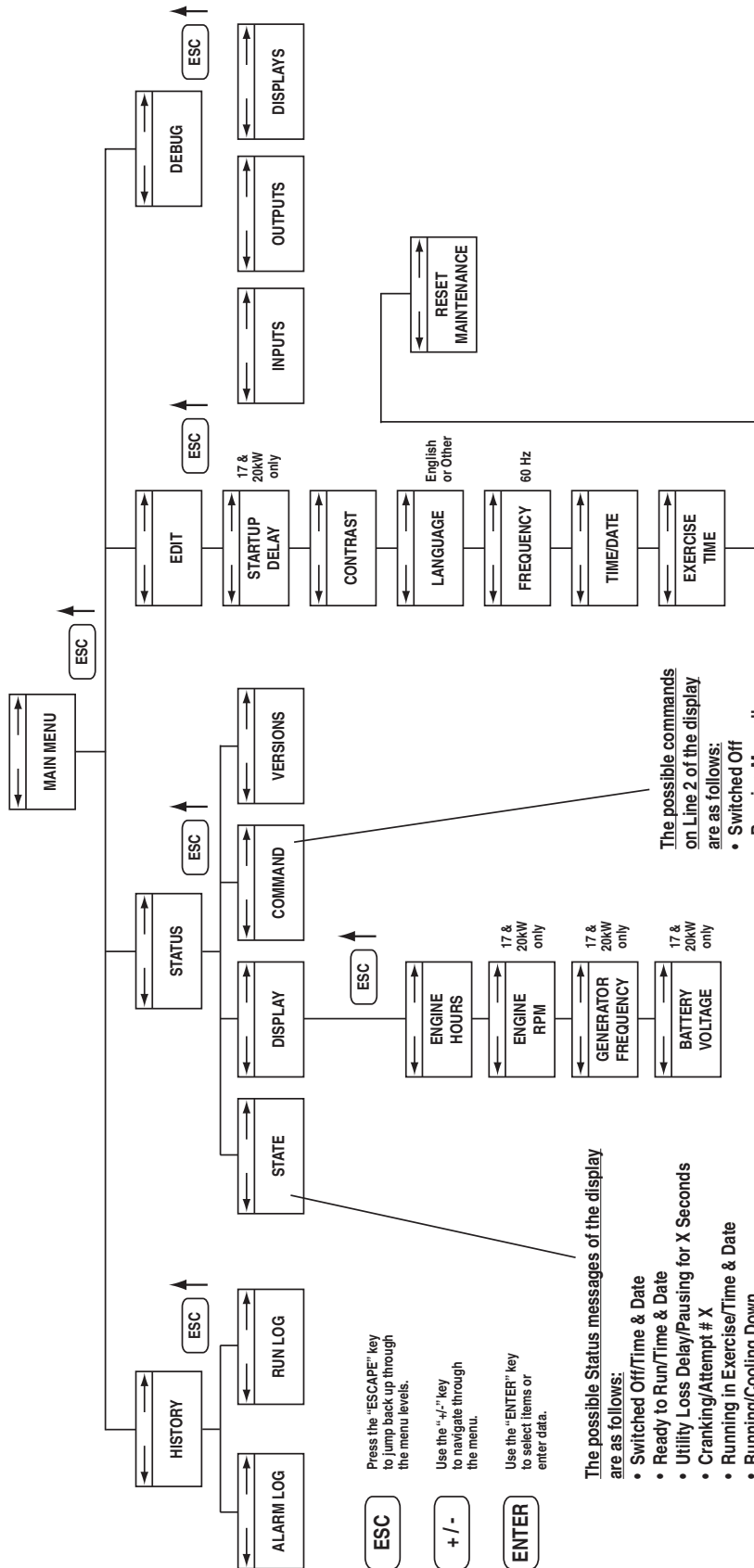

- ESC** Press the "ESCAPE" key to jump back up through the menu levels.
- + / -** Use the "+,/" key to navigate through the menu.
- ENTER** Use the "ENTER" key to select items or enter data.

- The possible Status messages of the display are as follows:
- Switched Off/Time & Date
 - Ready to Run/Time & Date
 - Utility Loss Delay/Pausing for X Seconds
 - Cranking/Attempt # X
 - Running in Exercise/Time & Date
 - Running/Cooling Down
 - Running - Warning/Warming Message
 - Running - Alarm/Alarm Message
 - Stopped - Alarm/Alarm Message
 - Stopped - Warning/Warming Message
 - Cranking/Pausing for X Seconds
 - Running/Time & Date
 - Running/Warming Up
 - Cranking - Warning/Warming Message
 - Cranking - Alarm/Alarm Message

- The possible commands on Line 2 of the display are as follows:
- Switched Off
 - Running Manually
 - Stopped in Auto Mode
 - Running - Utility Lost
 - Running in Exercise
 - Running from Radio



Section 7 — Installation Diagrams

Air-cooled Generators

Typical Non-Service Entrance Type

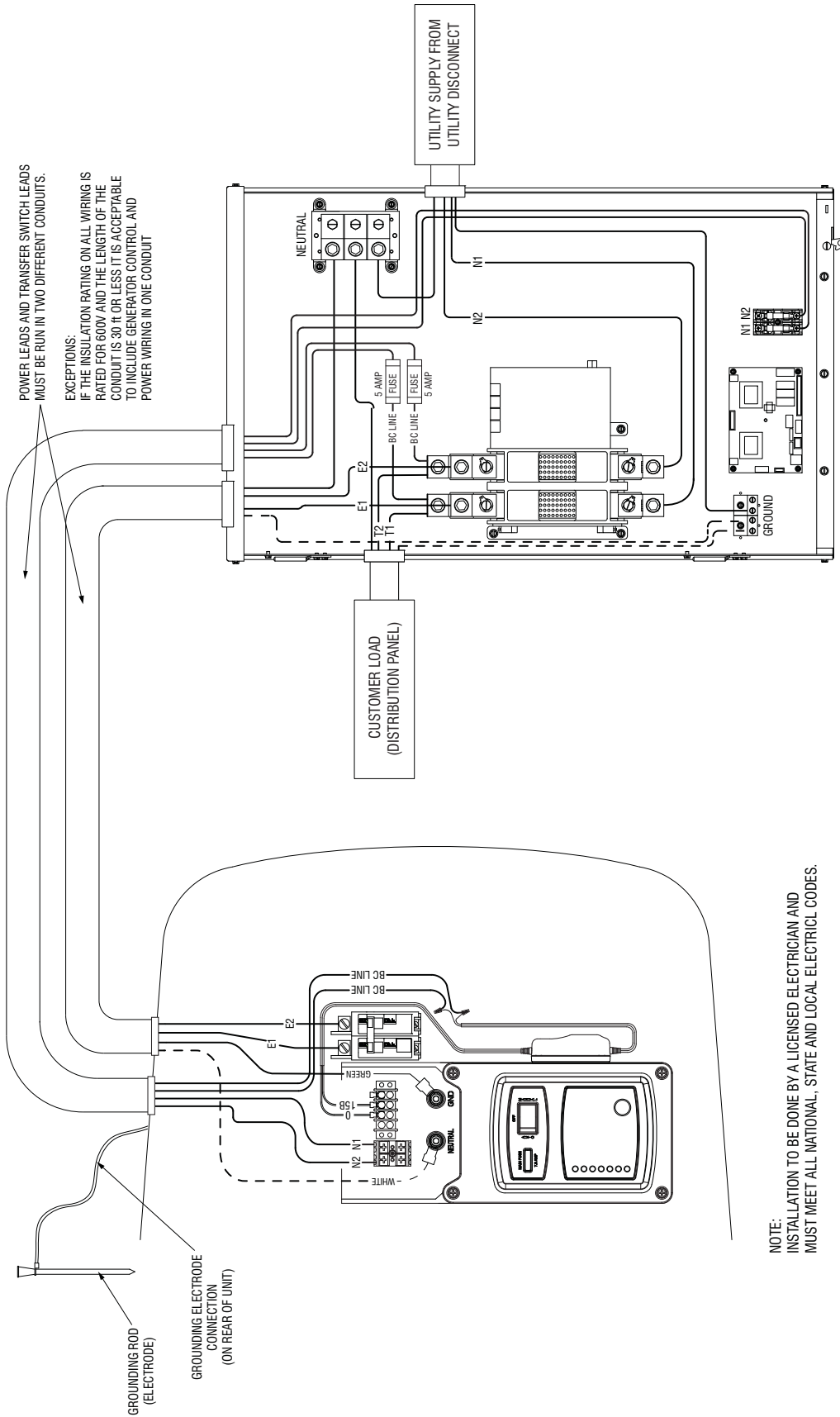

NOTE:
INSTALLATION TO BE DONE BY A LICENSED ELECTRICIAN AND MUST MEET ALL NATIONAL, STATE AND LOCAL ELECTRICAL CODES.

TYPICAL FOR ALL EATON NON-SERVICE ENTRANCE RATED TRANSFER SWITCHES.

Section 7 — Installation Diagrams

Air-cooled Generators Typical Service Entrance Type

INSTALLATION

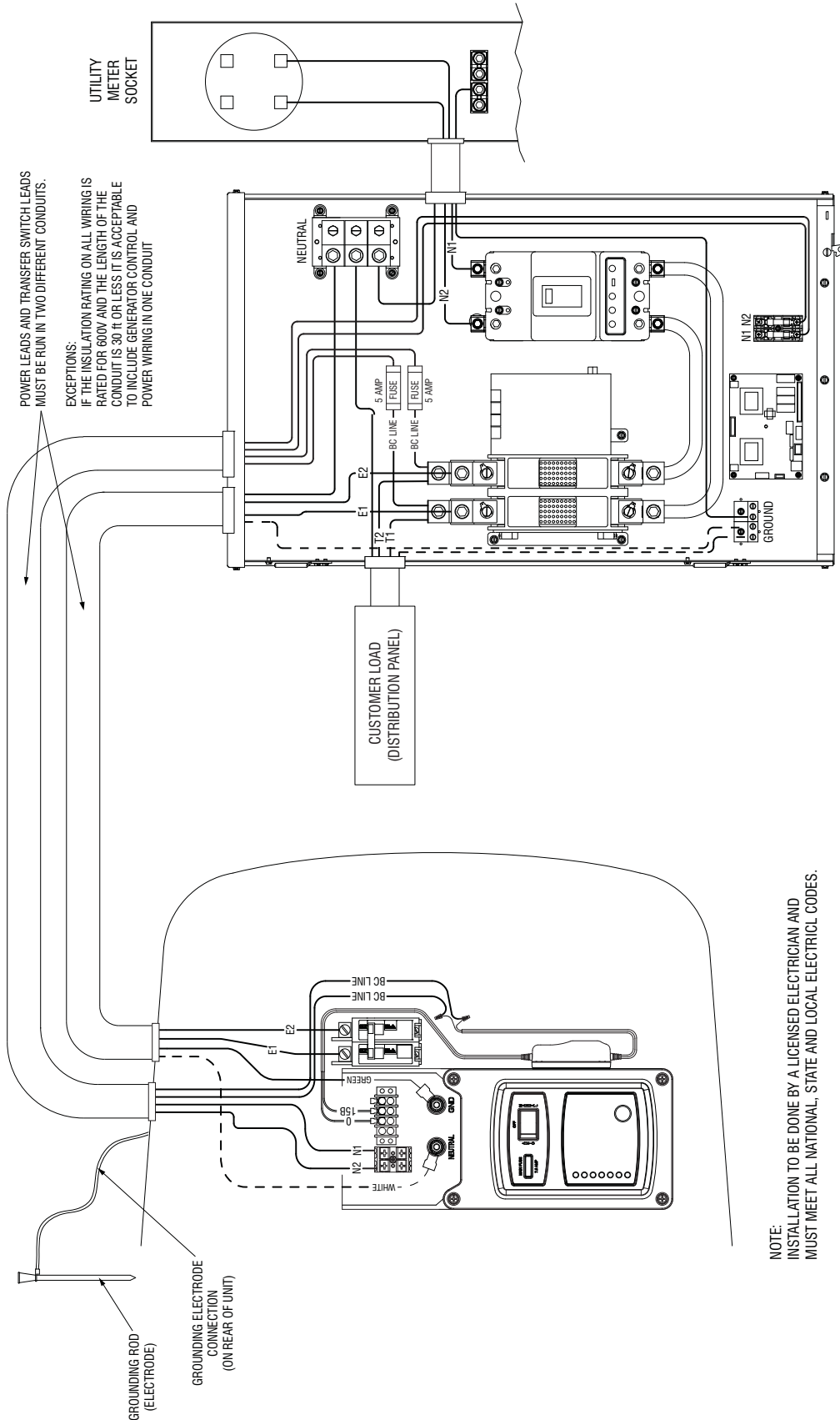
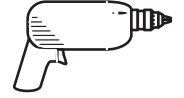

TYPICAL FOR ALL EATON SERVICE ENTRANCE RATED TRANSFER SWITCHES.

INSTALLATION

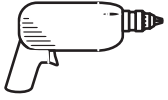

Section 7 — Installation Diagrams

**Air-cooled Generators
Generator - Drawing No. 0G8280-D**

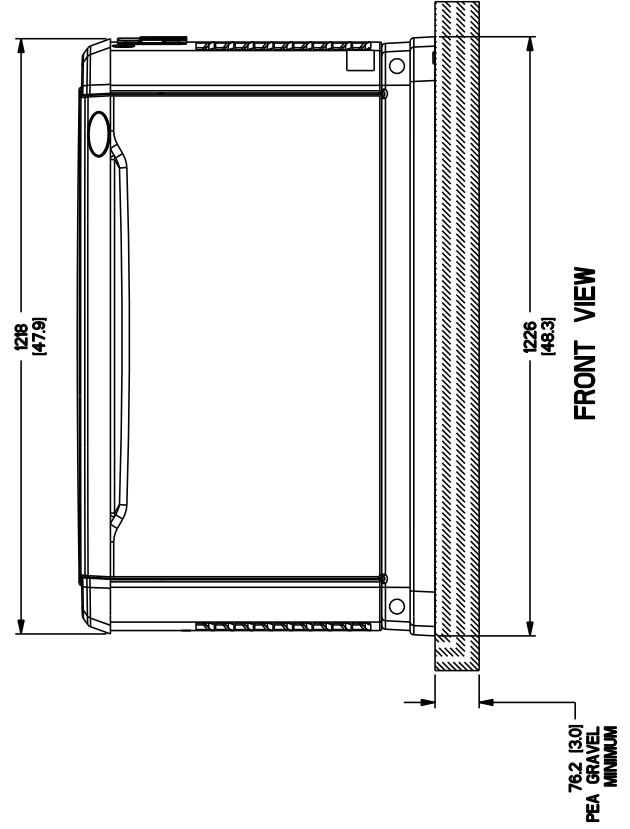
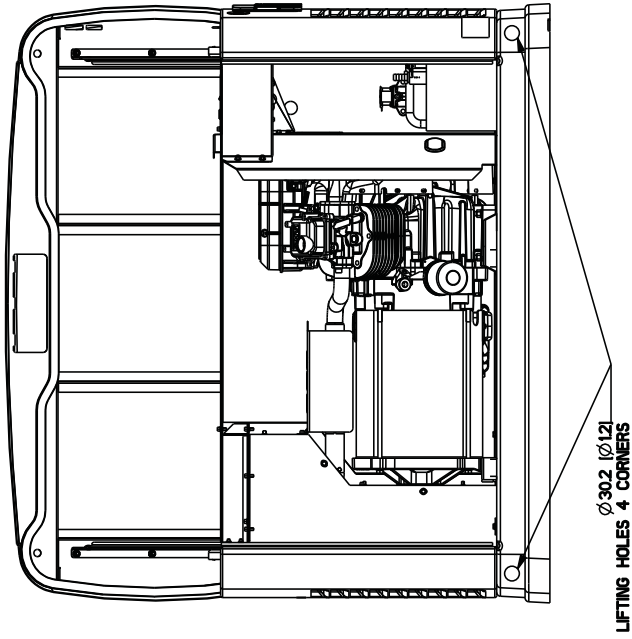

“DO NOT LIFT BY ROOF”

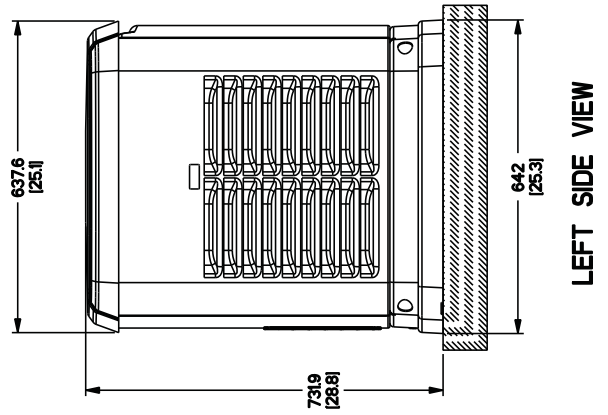

Section 7 — Installation Diagrams

Air-cooled Generators
Generator - Drawing No. 0G8280-D

INSTALLATION

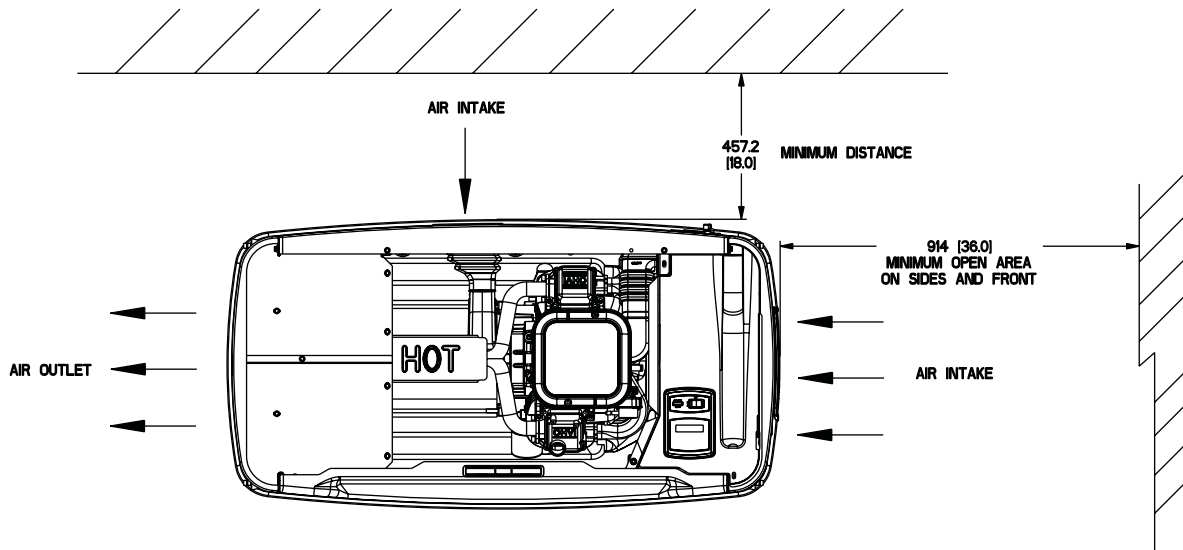
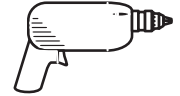

TOP VIEW

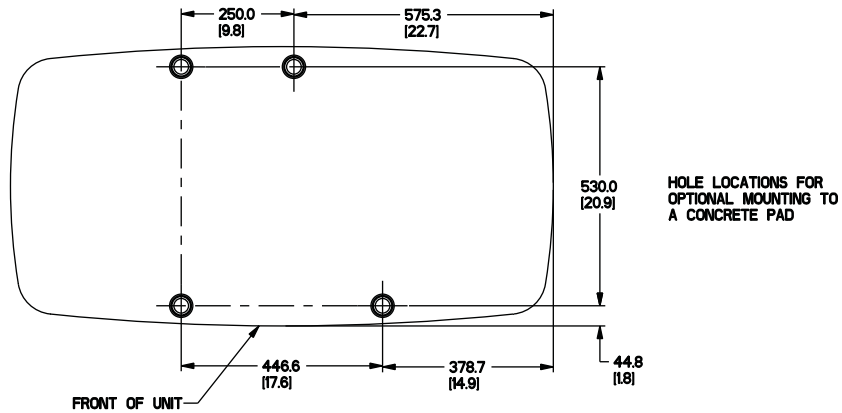

FUEL INLET - 12-20KW (1/2" NPT)
8 & 10KW (3/4" NPT) - USE SUPPLIED ADAPTER

REQUIRED FUEL PRESSURE: NATURAL GAS : 5-7" WATER COLUMN
LIQUID PROPANE (VAPOR) : 10-12" WATER COLUMN

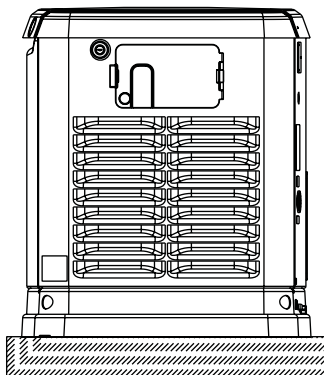

RIGHT SIDE VIEW

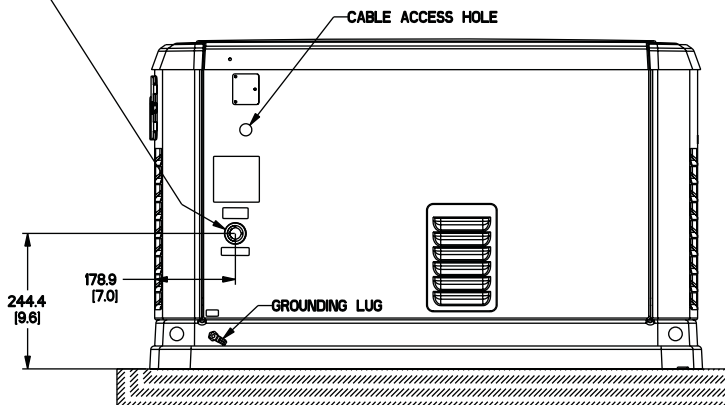

REAR VIEW

•ALL DIMENSIONS IN:
MILLIMETERS [INCHES]



Section 8 – Warranty

Air-cooled Generators

NOTE: This Emission Control Warranty Statement pertains to this product only IF the generator size is 15 kW or below.

CALIFORNIA EMISSION CONTROL WARRANTY STATEMENT

YOUR WARRANTY RIGHTS AND OBLIGATIONS

The California Air Resources Board (CARB) and Generac Power Systems, Inc. (Generac) are pleased to explain the Emission Control System Warranty on your new engine.* In California, new utility, and lawn and garden equipment engines must be designed, built and equipped to meet the state's stringent anti-smog standards. Generac will warrant the emission control system on your engine for the periods of time listed below provided there has been no abuse, neglect, unapproved modification or improper maintenance of your engine.

Your emission control system may include parts such as the carburetor, ignition system and exhaust system. Generac will repair your engine at no cost to you for diagnosis, replacement parts and labor, should a warrantable condition occur.

MANUFACTURER'S EMISSION CONTROL SYSTEM WARRANTY COVERAGE:

Emissions control systems on 1995 and later model year engines are warranted for two years as hereinafter noted. If, during such warranty period, any emission-related component or system on your engine is found to be defective in materials or workmanship, repairs or replacement will be performed by a Generac Authorized Warranty Service Facility.

PURCHASER'S/OWNER'S WARRANTY RESPONSIBILITIES:

As the engine purchaser/owner, you are responsible for the completion of all required maintenance as listed in your factory supplied *Owner's Manual*. For warranty purposes, Generac recommends that you retain all receipts covering maintenance on your engine. However, Generac cannot deny warranty solely due to the lack of receipts or for your failure to ensure the completion of all scheduled maintenance.

As the engine purchaser/owner, you should, however, be aware that Generac may deny any and/or all warranty coverage or responsibility if your engine, or a part/component thereof, has failed due to abuse, neglect, improper maintenance or unapproved modifications, or the use of counterfeit and/or "grey market" parts not made, supplied or approved by Generac.

You are responsible for contacting a Generac Authorized Warranty Service Facility as soon as a problem occurs. The warranty repairs should be completed in a reasonable amount of time, not to exceed 30 days.

Warranty service can be arranged by contacting either your selling dealer or a Generac Authorized Warranty Service Facility. To locate the Generac Authorized Warranty Service Facility nearest you, call our toll-free number:

1-800-333-1322

IMPORTANT NOTE: This warranty statement explains your rights and obligations under the Emission Control System Warranty (ECS Warranty), which is provided to you by Generac pursuant to California law. See also the "Generac Limited Warranties for Generac Power Systems, Inc.," which is enclosed herewith on a separate sheet, also provided to you by Generac. The ECS Warranty applies **only** to the emission control system of your new engine. If there is any conflict in terms between the ECS Warranty and the Generac Warranty, the ECS Warranty shall apply except in circumstances where the Generac Warranty may provide a longer warranty period. Both the ECS Warranty and the Generac Warranty describe important rights and obligations with respect to your new engine.

Warranty service can be performed only by a Generac Authorized Warranty Service Facility. When requesting warranty service, evidence must be presented showing the date of the sale to the original purchaser/owner.

If you have any questions regarding your warranty rights and responsibilities, you should contact Generac at one of the following addresses:

For Air-cooled Product ...

**ATTENTION WARRANTY DEPARTMENT
GENERAC POWER SYSTEMS, INC.
P.O. BOX 297
WHITEWATER, WI 53190**

Part 1

For Liquid-cooled Product ...

**ATTENTION WARRANTY DEPARTMENT
GENERAC POWER SYSTEMS, INC.
211 MURPHY DRIVE
EAGLE, WI 53119**



EMISSION CONTROL SYSTEM WARRANTY

Emission Control System Warranty (ECS Warranty) for 1995 and later model year engines:

- (a) **Applicability:** This warranty shall apply to 1995 and later model year engines. The ECS Warranty Period shall begin on the date the new engine or equipment is purchased by/delivered to its original, end-use purchaser/owner and shall continue for 24 consecutive months thereafter.
- (b) **General Emissions Warranty Coverage:** Generac warrants to the original, end-use purchaser/owner of the new engine or equipment and to each subsequent purchaser/owner that each of its engines is ...
 - (1) Designed, built and equipped so as to conform with all applicable regulations adopted by the CARB pursuant to its authority, and
 - (2) Free from defects in materials and workmanship which, at any time during the ECS Warranty Period, may cause a warranted emissions-related part to fail to be identical in all material respects to the part as described in the engine manufacturer's application for certification.
- (c) The ECS Warranty only pertains to emissions-related parts on your engine, as follows:
 - (1) Any warranted, emissions-related parts that are not scheduled for replacement as required maintenance in the *Owner's Manual* shall be warranted for the ECS Warranty Period. If any such part fails during the ECS Warranty Period, it shall be repaired or replaced by Generac according to Subsection (4) below. Any such part repaired or replaced under the ECS Warranty shall be warranted for the remainder of the ECS Warranty Period.
 - (2) Any warranted, emissions-related part that is scheduled only for regular inspection as specified in the *Owner's Manual* shall be warranted for the ECS Warranty Period. A statement in such written instructions to the effect of "repair or replace as necessary" shall not reduce the ECS Warranty Period. Any such part repaired or replaced under the ECS Warranty shall be warranted for the remainder of the ECS Warranty Period.
 - (3) Any warranted, emissions-related part that is scheduled for replacement as required maintenance in the *Owner's Manual* shall be warranted for the period of time prior to the first scheduled replacement point for that part. If the part fails prior to the first scheduled replacement, the part shall be repaired or replaced by Generac according to Subsection (4) below. Any such emissions-related part repaired or replaced under the ECS Warranty shall be warranted for the remainder of the ECS Warranty Period prior to the first scheduled replacement point for such emissions-related part.
 - (4) Repair or replacement of any warranted, emissions-related part under this ECS Warranty shall be performed at no charge to the owner at a Generac Authorized Warranty Service Facility.
 - (5) When the engine is inspected by a Generac Authorized Warranty Service Facility, the owner shall not be held responsible for diagnostic costs if the repair is deemed warrantable.
 - (6) Generac shall be liable for damages to other original engine components or approved modifications proximately caused by a failure under warranty of any emission-related part covered by the ECS Warranty.
 - (7) Throughout the ECS Warranty Period, Generac shall maintain a supply of warranted emission-related parts sufficient to meet the expected demand for such emission-related parts.
 - (8) Any Generac authorized and approved emission-related replacement part may be used in the performance of any ECS Warranty maintenance or repairs and will be provided without charge to the owner. Such use shall not reduce Generac ECS Warranty obligations.
 - (9) Unapproved, add-on, modified, counterfeit and/or "grey market" parts may not be used to modify or repair a Generac engine. Such use voids this ECS Warranty and shall be sufficient grounds for disallowing an ECS Warranty claim. Generac shall not be held liable hereunder for failures of any warranted parts of a Generac engine caused by the use of such an unapproved, add-on, modified, counterfeit and/or "grey market" part.

EMISSION RELATED PARTS INCLUDE THE FOLLOWING:

- 1) Fuel Metering System:
 - a) Spark plug
 - b) Ignition module
- 1.2) LPG/Natural Gas carburetion assembly and its internal components.
 - a) Fuel controller (if so equipped)
 - b) Mixer and its gaskets (if so equipped)
 - c) Carburetor and its gaskets (if so equipped)
 - d) Primary gas regulator (if so equipped)
 - e) LP liquid vaporizer (if so equipped)
- 2) Air Induction System including:
 - a) Intake pipe/manifold
 - b) Air cleaner
- 3) Ignition System including:
 - a) Catalytic Muffler Assembly (if so equipped) including:
 - a) Muffler gasket
 - b) Exhaust manifold
 - 5) Crankcase Breather Assembly including:
 - a) Breather connection tube

*Generac engine types covered by this warranty statement include the following:

- 1) Prepackaged Standby Generator
- 2) Auxiliary Power Unit (APU) Generator
- 3) Standby Generator

