

TOSHIBA/HOUSTON

TOTALLY-ENCLOSED FAN-COOLED  
HORIZONTAL FOOT-MOUNTED

Fr. 364T/TS-365T/TS

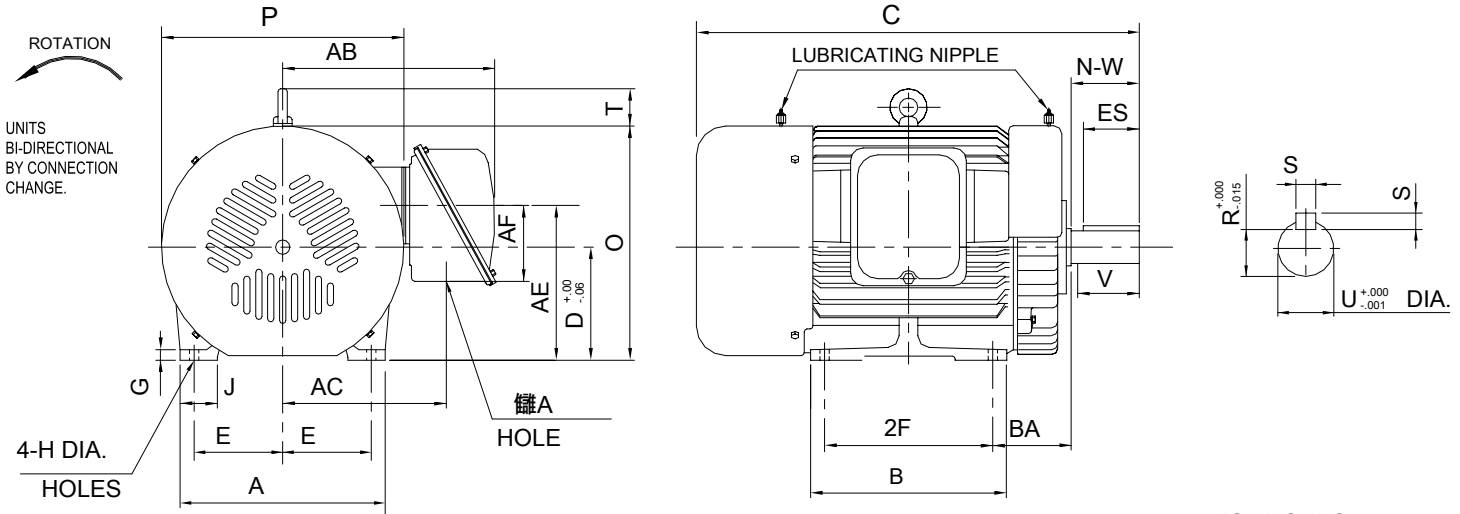

FRAME SIZE	MOUNTING				CONDUIT BOX						
	E	2F	H	BA	AA	AB	AC	AE	AF	XL	XN
364T/364TS	7.00	11.25	0.66	5.88	3.58	17.32	12.8	12.1	6.3	—	—
365T/365TS	7.00	12.25	0.66	5.88	3.58	17.32	12.8	12.1	6.3	—	—

FRAME SIZE	MOTOR DIMENSIONS								
	A	B	C	D	G	J	O	T	P
364TS	16.4	14.4	30.41	9.00	0.93	3.15	18.4	2.9	19.1
364T	16.4	14.4	32.54	9.00	0.93	3.15	18.4	2.9	19.1
365TS	16.4	15.4	31.39	9.00	0.93	3.15	18.4	2.9	19.1
365T	16.4	15.4	33.52	9.00	0.93	3.15	18.4	2.9	19.1

FRAME SIZE	SHAFT EXTENSION			KEY SEAT			BEARINGS		MAXIMUM WEIGHT
	N-W	V	U	R	S	ES	LS	OS	
364T/365T	5.88	5.75	2.375	2.021	0.625	4.28	NU215	6312	580 lbs.
364TS/365TS	3.75	3.50	1.875	1.591	0.500	2.03	6312C3	6312C3	610 lbs.

ALL DATA SUBJECT TO CHANGE WITHOUT NOTICE.  
FOR CONSTRUCTION USE ONLY CERTIFIED DATA.

**CERTIFIED DATA**

- NOTES:
1. DIMENSION V REPRESENTS LENGTH OF STRAIGHT PART OF SHAFT.
  2. CONDUIT BOX MAY BE ROTATED IN 90° INCREMENTS AND MAY BE MOUNTED ON OPPOSITE SIDE ON SPECIAL ORDER.
  3. KEY DIMENSIONS EQUAL S x S x 2.88 (MOTOR SUPPLIED WITH KEY)
  4. MOTOR WEIGHT SHOWN IS MAXIMUM HORSEPOWER IN FRAME.

CUSTOMER: \_\_\_\_\_ P.O. NO.: \_\_\_\_\_ TAG NO.: \_\_\_\_\_

MOTOR MODEL NO.: \_\_\_\_\_ TOSHIBA FILE NO.: \_\_\_\_\_

HP: \_\_\_\_\_ RPM (SYN.): \_\_\_\_\_ VOLTAGE: \_\_\_\_\_ Hz: \_\_\_\_\_

FRAME SIZE: \_\_\_\_\_ LOG NO.: \_\_\_\_\_ LOG REV. LEVEL: \_\_\_\_\_

REMARKS: \_\_\_\_\_

PER: \_\_\_\_\_ ISSUE DATE: \_\_\_\_\_ SUPERSEDES: \_\_\_\_\_