

TOSHIBA/HOUSTON

TOTALLY-ENCLOSED FAN-COOLED Fr. 447T/TS-449T/TS
HORIZONTAL FOOT-MOUNTED

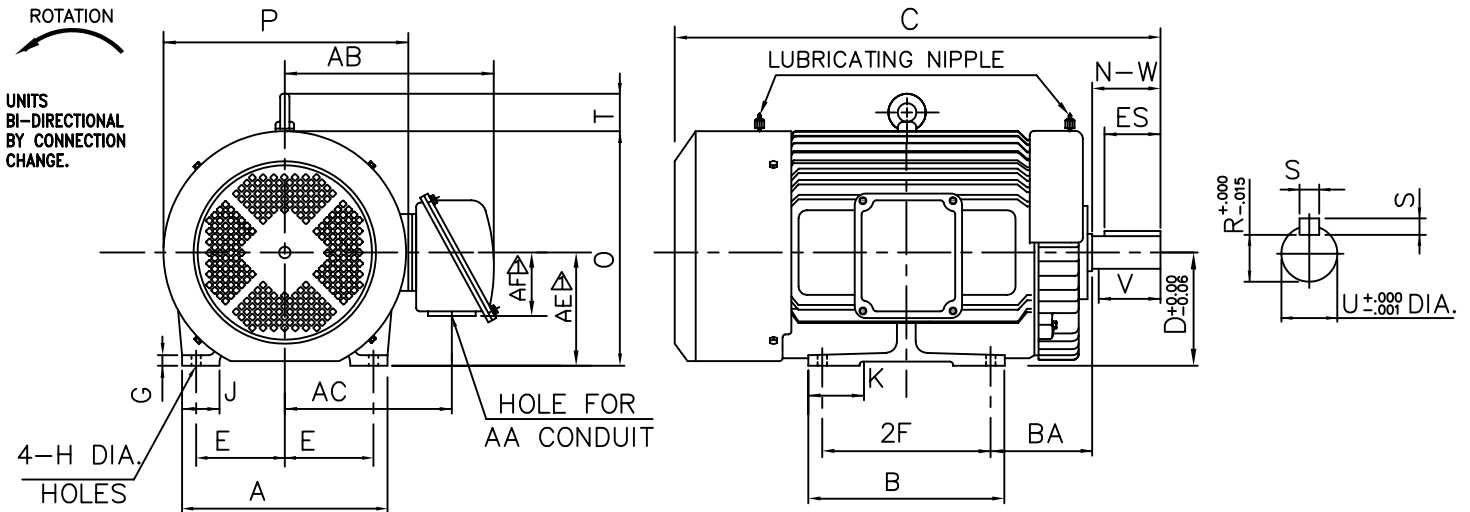

FRAME SIZE	MOUNTING				CONDUIT BOX						
	E	2F	H	BA	AA	AB	AC	AE	AF	XL	XN
447T/447TS	9.00	20.00	0.81	7.50	NPT3 1/2"	22.95	17.63	11.00	9.94	--	--
449T/449TS	9.00	25.00	0.81	7.50	NPT3 1/2"	22.95	17.63	11.00	9.94	--	--

FRAME SIZE	MOTOR DIMENSIONS									
	A	B	C	D	G	J	K	O	T	P
447T	22.05	27.83	57.52	11.00	1.18	4.33	5.71	23.50	4.33	26.77
447TS	22.05	27.83	53.77	11.00	1.18	4.33	5.71	23.50	4.33	26.77
449T	22.05	27.83	57.52	11.00	1.18	4.33	5.71	23.50	4.33	26.77
449TS	22.05	27.83	53.77	11.00	1.18	4.33	5.71	23.50	4.33	26.77

FRAME SIZE	SHAFT EXTENSION			KEY SEAT			BEARINGS		MAXIMUM WEIGHT
	N-W	V	U	R	S	ES	LS	OS	
447T	8.50	8.25	3.375	2.880	0.875	6.91	NU220	6315	2460 lbs.
447TS	4.75	4.50	2.375	2.021	0.625	3.03	6313C3	6313C3	2430 lbs.
449T	8.50	8.25	3.375	2.880	0.875	6.91	NU320	6318	2778 lbs.
449TS	4.75	4.50	2.375	2.021	0.625	3.03	6313C3	6313C3	2750 lbs.

- NOTES:
- DIMENSION V REPRESENTS LENGTH OF STRAIGHT PART OF SHAFT.
 - CONDUIT BOX MAY BE ROTATED IN 90° INCREMENTS AND MAY BE MOUNTED ON OPPOSITE SIDE ON SPECIAL ORDER.
 - "T" KEY DIMENSIONS EQUAL S x S x 6.875
"TS" KEY DIMENSIONS EQUAL S x S x 3.000 (MOTOR SUPPLIED WITH KEY)
 - MOTOR WEIGHT SHOWN IS MAXIMUM HORSEPOWER IN FRAME.

ALL DATA SUBJECT TO CHANGE WITHOUT NOTICE.
FOR CONSTRUCTION USE ONLY CERTIFIED DATA.

CERTIFIED DATA

CUSTOMER: _____ P.O. NO.: _____ TAG NO.: _____

MOTOR MODEL NO.: _____ TOSHIBA FILE NO.: _____

HP: _____ RPM (SYN.): _____ VOLTAGE: _____ Hz: _____

FRAME SIZE: _____ LOG NO.: _____ LOG REV. LEVEL: _____

REMARKS: _____

PER: _____ ISSUE DATE: _____ SUPERSEDES: _____