

INDEX	OL-44164
REV. LEVEL	0
SHEET	1 OF 1

TOSHIBA/HOUSTON **TOTALLY-ENCLOSED FAN-COOLED**
HORIZONTAL FOOT-MOUNTED **BELT DRIVE**
QUARRY-DUTY (C.I. T-BOX) **Fr. 447T**

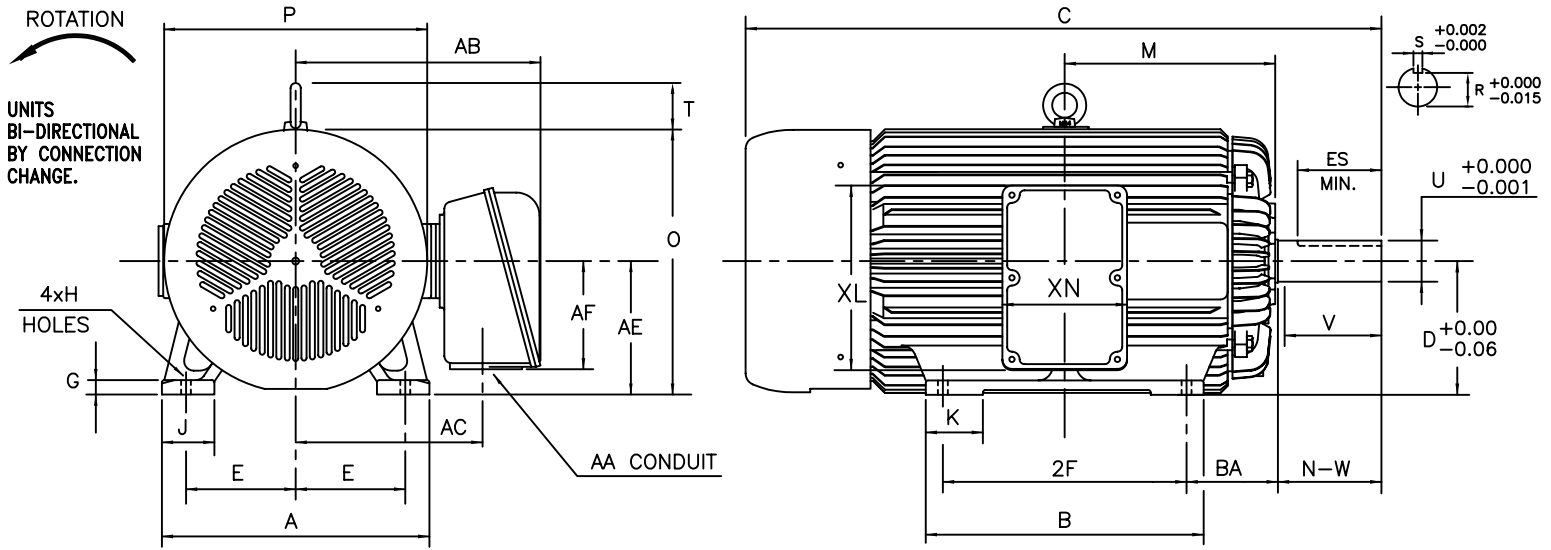

UNITS: INCHES

FRAME SIZE	MOUNTING				CONDUIT BOX						
	E	2F	H	BA	AA	AB	AC	AE	AF	XL	XN
447T	9.00	20.00	0.81	7.50	3.00	20.1	15.8	11.0	9.2	15.2	10.2

FRAME SIZE	MOTOR DIMENSIONS										
	A	B	C	D	G	J	K	M	O	P	T
447T	22.0	22.8	52.2	11.00	1.2	4.3	4.7	17.3	22.0	21.6	3.9

FRAME SIZE	SHAFT EXTENSION			KEY SEAT			BEARINGS		MAXIMUM WEIGHT
	N-W	V	U	R	S	ES	LS	OS	
447T	8.50	8.25	3.375	2.88	0.875	8.53	NU318C3	6318C3	2314 lbs.

ALL DATA SUBJECT TO CHANGE WITHOUT NOTICE.
FOR CONSTRUCTION USE ONLY CERTIFIED DATA.

CERTIFIED DATA

- NOTES:
1. DIMENSION V REPRESENTS LENGTH OF STRAIGHT PART OF SHAFT.
 2. CONDUIT BOX MAY BE ROTATED IN 90° INCREMENTS AND MAY BE MOUNTED ON OPPOSITE SIDE ON SPECIAL ORDER.
 3. KEY DIMENSIONS EQUAL S x S x 6.88 (MOTOR SUPPLIED WITH KEY)
 4. MOTOR WEIGHT SHOWN IS MAXIMUM HORSEPOWER IN FRAME.

CUSTOMER: _____ P.O. NO.: _____ TAG NO.: _____
MOTOR MODEL NO.: _____ TOSHIBA FILE NO.: _____
HP: _____ RPM (SYN.): _____ VOLTAGE: _____ Hz: _____
FRAME SIZE: _____ LOG NO.: _____ LOG REV. LEVEL: _____
REMARKS: _____
PER: _____ ISSUE DATE: _____ SUPERSEDES: _____